



# TW S3-18U

Short Platform Scissor Lift  
In-ground Installation  
Manual Leveling  
Lifting Capacity: 3000 KG

twinbusch.de



Installation, Operation and Parts Manual



Please read this entire manual carefully and completely before installation or operation of the lift.

Twin Busch GmbH | Amperestraße 1 | D-64625 Bensheim  
Tel.: +49 (0) 6251-70585-0 | Fax: +49 (0) 6251-70585-29 | info@twinbusch.de



TWIN BUSCH GmbH

# INDEX

<b>1. Important safety instructions.....</b>	<b>3~4</b>
1.1 Important notices	
1.2 Qualified personnel	
1.3 Danger notices	
1.4 Training	
1.5 Warning signs	
<b>2. Overview of the lift.....</b>	<b>5</b>
2.1 General descriptions	
2.2 Technical data	
2.3 Construction of the lift	
<b>3. Installation instructions.....</b>	<b>6~7</b>
3.1 Preparations before installation	
3.1.1 Tools and equipments needed	
3.1.2 A list for parts checking	
3.1.3 Ground conditions	
3.2 Precautions for installation	
3.3 Installation	
3.4 Items to be checked after installation	
<b>4. Operation instructions.....</b>	<b>8~10</b>
4.1 Precautions	
4.2 Descriptions of control box	
4.3 Flow chart for operation	
4.4 Operating instructions	
4.5 Emergency lowering in case of no power	
<b>5. Trouble shooting.....</b>	<b>11</b>
<b>6. Maintenance.....</b>	<b>12</b>
<b>7. Annex.....</b>	<b>13~28</b>
Annex1, Packing list of the whole lift	
Annex2, Overall diagram	
Annex3, Floor plan	
Annex4, Diagram for oil hose connection	
Annex 5, Hydraulic working system	
Annex6, Wiring diagram	
Annex7, Diagram for air supply connection	
Annex8, Separated drawings for the lift	
Annex9, Spare parts list	

## IMPORTANT SAFETY INSTRUCTIONS

### 1.1 Important notices

We will offer one-year's quality warranty for the whole machine, during which any quality problem will be properly solved to the user's satisfaction. However, we will not take any responsibility for whatever bad consequence resulted from improper installation and operation, overload running or unqualified ground condition. This model is specially designed for lifting motor vehicles that weighs within its outmost lifting capacity. Users are not allowed to use it for any other purposes. Otherwise, we, as well as our sales agency, will not bear any responsibility for accidents or damages of the lift. Make sure to pay careful attention to the label of the lifting capacity attached on the lift and never try to lift cars with its weight beyond. Read this manual carefully before operating the machine so as to avoid economic loss or personnel casualty incurred by wrong operation. Without our professional advice, users are not permitted to make any modification to the control unit or whatever mechanical unit.

### 1.2 Qualified personnel

1.2.1 Only these qualified staff, who have been properly trained, can operate the lift.

1.2.2 Electrical connection must be done by a competent electrician.

1.2.3 People who are not concerned are not allowed in the lifting area.

### 1.3 Danger notices

1.3.1 Do not install the lift on any asphalt surface.

1.3.2 Read and understand all safety warnings before operating the lift.

1.3.3 Do not leave the controls while the lift is still in motion.

1.3.4 Keep hands and feet away from any moving parts. Keep feet clear of the lift when lowering.

1.3.5 Only these properly trained personnel can operate the lift.

1.3.6 Do not wear unfit clothes such as large clothes with flounces, tires, etc, which could be caught by moving parts of the lift.

1.3.7 To prevent evitable incidents, surrounding areas of the lift must be tidy and with nothing unconcerned.

1.3.8 The lift is simply designed to lift the entire body of vehicles, with its maximum weight within the lifting capacity.

1.3.9 Always insure the safety locks are engaged before any attempt to work near or under the vehicle. Never remove safety related components from the lift. Do not use if safety related components are damaged or missing.

1.3.10 Do not rock the vehicle while on the lift or remove any heavy component from vehicle that may cause excessive weight shift.

1.3.11 Check at any time the parts of the lift to ensure the agility of moving parts and the performance of synchronization. Ensure regular maintenance and if anything abnormal occurs, stop using the lift immediately and contact our dealers for help.

1.3.12 Lower the lift to its lowest position and do remember to cut off the power source when service finishes.

1.3.13 Do not modify any parts of the lift without manufacturer's advice.

1.3.14 If the lift is going to be left unused for a long time, users are required to:

- a. Disconnect the power source;
- b. Empty the oil tank;
- c. Lubricate the moving parts with hydraulic oil.

### 1.4 Training

Only these qualified people, who have been properly trained, can operate the lift. We are quite willing to provide professional training for the users when necessary.

**Attention: For environment protection, please dispose the disused oil in a proper way.**

### 1.5 Warning signs

All safety warning labels are clearly depicted on the lift to ensure that the operator is aware of dangers during operation.

Warning labels should be kept clean and replaced when damaged or missing.



## OVERVIEW OF THE LIFT

### 2.1 General descriptions

This model is in-ground mounted and is mainly composed by two lifting platforms, two base plates, two oil cylinders and a set of power unit. The gear pump works when power supply is connected and meanwhile oil in the pump will push upwards the pistons of oil cylinders. Thus, scissor brackets of the lift rise accordingly. In the process of rising, the mechanical lock will automatically engaged so as to avoid sudden drop down caused by failure of hydraulic system.

Besides, designs like, 24V working voltage of control box and limit switch, low-height alarming buzzer, anti-surge valves, etc have fully considered your personal security.

Safety structure:

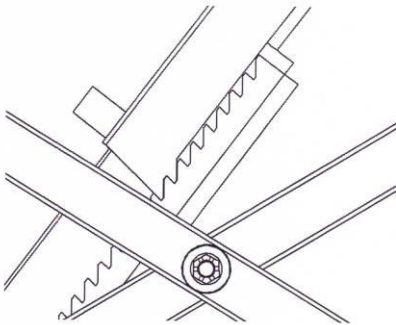

### 2.2 Technical data

Model	Lifting capacity	Lifting time	Lifting height	Electrical requirement
TW S3-18U	3000kg	50 Sec	1820mm	400V, Three Phase

### 2.3 Construction of the lift

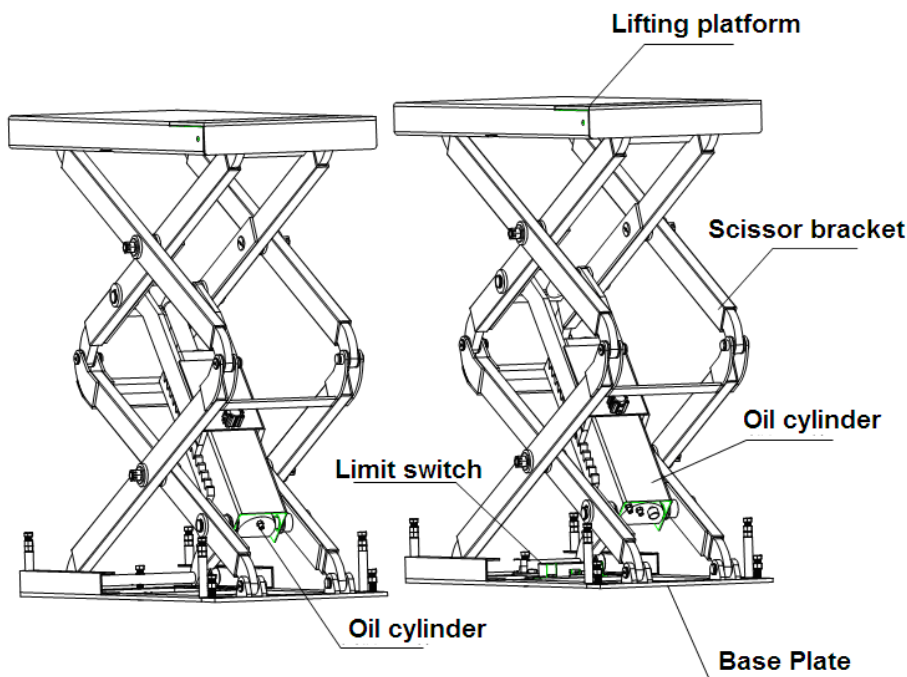

## INSTALLATION INSTRUCTIONS

### 3.1 Preparations before installation

#### 3.1.1 Tools and equipments needed

- √ Electrical drill
- √ Open wrenches
- √ Screw drivers
- √ Adjustable spanner

#### 3.1.2 List for parts checking ---Annex 1 ( Packing list )

Unfold the package and check if any parts missed as per Annex 1. Do not hesitate to contact us in case any parts missed, but if you do not contact us and insist installing upon the lack of some parts, we as well as our dealers will not bear any responsibility for this and will charge for any parts subsequently demanded by the buyer.

#### 3.1.3 Ground conditions

The lift should be fixed on a smooth and solid concrete ground with its strength more than 3000psi, tolerance of flatness less than 5mm and minimum thickness of 200mm. In addition, newly built concrete ground must undergo more than 28days' cure and reinforcement.

### 3.2 Precautions for installation

3.2.2 Joints of oil hose and wiring must be firmly connected in order to avoid leakage of oil hose and looseness of electrical wires.

3.2.3 All bolts should be firmly screwed up.

3.2.4 Do not place any vehicle on the lift in the case of trial running.

### 3.3 Installation

#### Step1: Choose installation site.

Use a fork lift to place the machine at installation site as required. See **Annex 3** for space requirements on the installation site.

#### Step 2: Connect oil hoses.

Connect oil hoses as per the diagram for oil hose connection and the following pictures. (This step is very important and it is quite necessary to understand the diagram of oil hose connection in Annex 4 before operation)

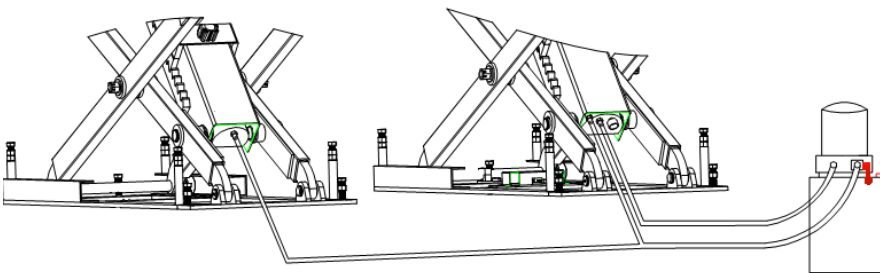

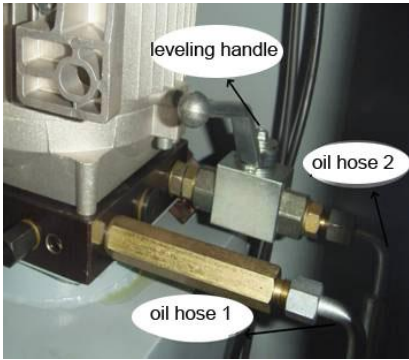

**Step 3: Connect the pneumatic release system by referring the following pictures.**

Connect the pneumatic release system by referring the following pictures.

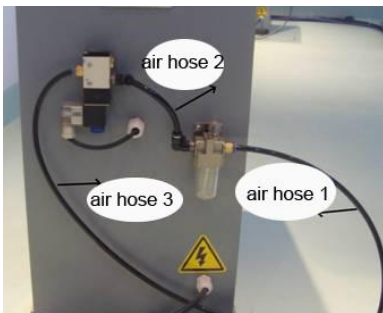

Notes: Air hose 1 is to be connected between the compressed air supply and air filter.

Air hose 3 is to be connected between two pneumatic solenoid valves on the control box and the drive oil cylinder.

Air hose 4 is to be connected with the pneumatic solenoid valve on the other cylinder.

**Step 4: Connect limit switch.**

Connect the power supply and the two quick plugs of the limit switch.

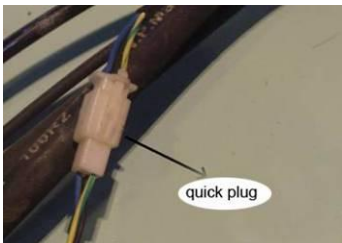

**Step 5: Fill hydraulic oil.**

Pour 16 liters of anti-abrasion hydraulic oil into the oil tank. The level of oil shall be 10mm to 40mm distance from the top of the tank. (You may measure by the feeler attached on the cover of the tank)

**Step 6: Leveling**

**Manual leveling:**

- 1) Connect the power supply and switch on the power button on the control panel until the green indicator light shines.
- 2) Switch the option switch in the control box to working condition and press the "UP" button for 30 seconds. Normally at least one of the platforms will rise at this movement. **(In the case the machine is equipped with three phase power supply and the motor works but the platform does not move upwards after the "UP" button has been pressed for 30 seconds, the operators needs to change the phase order of the motor's wiring)**
- 3) Manually open the valve in the control box by moving the handle pointing opposite to the hydraulic block and then you can press the "UP" or "DOWN" button to adjust the height of the assistant platform until it reached the same height as the main platform. Close the



valve by removing the handle to its initial position and press the “UP” and “DOWN” button to check the synchronization of the two platforms. If synchronization is still not achieved, repeat the above leveling steps until synchronization reached.

3.4 Items to be checked after installation.

S/N	Check items	YES	NO
1	Are two platforms adjusted with the same level?		
2	Are oil hose tightly connected?		
3	Are all electric connections correct?		
4	Are valves of the pump unit oil tight?		

## OPERATION INSTRUCTIONS

### 4.1 Precautions

4.1.1 Check all the joints of oil hose. Only when there is no leakage, the lift can start work.

4.1.2 The lift, if its safety device malfunctions, shall not be used.

4.1.3 The machine shall not lift or lower an automobile if its center of gravity is not positioned midway of the rising platforms. Otherwise, we as well as our dealers will not bear any responsibility for any consequence resulted thereby.

4.1.4 Operators and other personnel concerned should stand in a safety area during lifting and lowering process.

4.1.5 When platforms being raised to the desired height, switch off the power at once to prevent any wrong operation done by unconcerned people.

4.1.6. Make sure the safety lock of the lift is engaged before start working under the vehicle and no people under the vehicle during lifting and lowering process.

### 4.2 Descriptions of control box

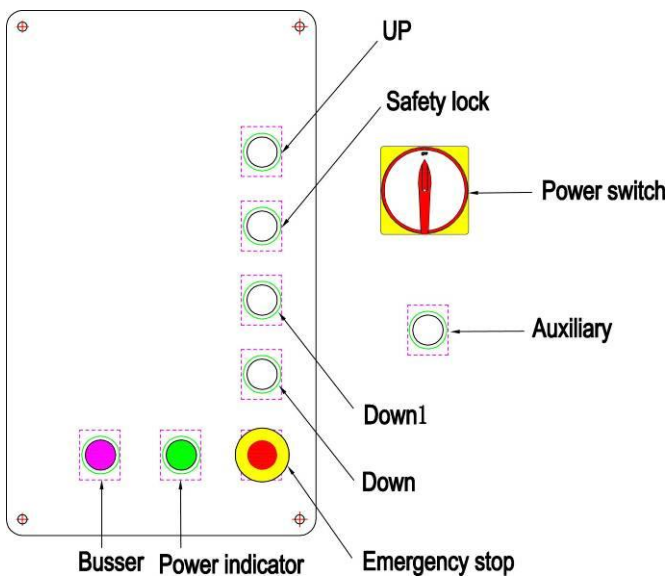

#### 4.3 Flow chart for operation

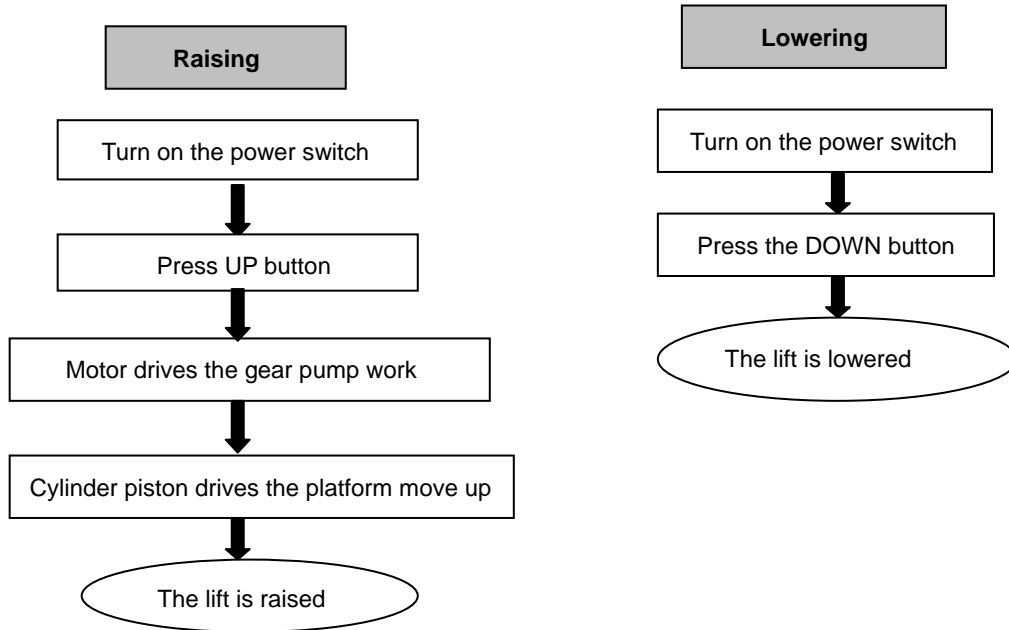

#### 4.4 Operation instructions

##### Raise the lift

1. Make sure that you have read and understood the operation manual before operation.
2. Drive and park the vehicle midway between two platforms.
3. Place the four rubber pads under the prop-points of the vehicle and ensure car's gravity have fallen on the rubber pads.
4. Press the "UP" button on the control box until rubber pads have touched the prop-points of vehicle.
5. Keep on pressing the "UP" button to lift the vehicle a bit higher from the ground and check again if the vehicle is in a safe position.
6. Having raised the vehicle to the required height, operators must press down the safety lock button to ensure the mechanical safety lock is engaged. Press the "Emergency Stop" until the power indicator is off and check again the stability before performing maintenance or repair work,

##### Lower the lift

1. Switch on.
2. Press the "DOWN I" button to lower the lift. It will stop lowering when clearance between the platforms and the ground reached to 500mm.
3. Press "DOWN II" button to continue lowering the platforms. Alarming buzz will be heard unless you stop pressing "DOWN II".
4. Drive the vehicle away

#### 4.5 Emergency lowering in case of no power

##### **Pneumatic lock is not engaged**

1. Pull up the safety teeth with steel rope to release the safety lock.

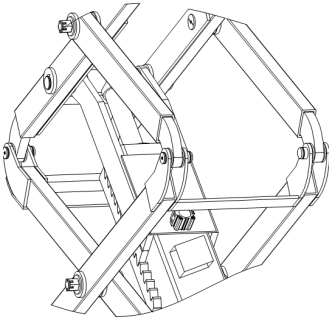

2. Screw loose the core of the solenoid unloading valve fixed on the hydraulic block.

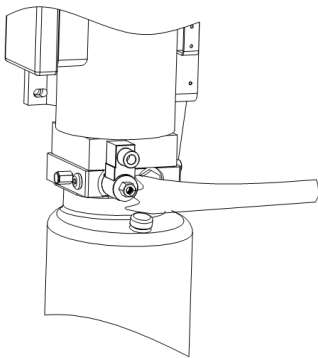

##### **Pneumatic safety lock is engaged.**

1. Take down the removable plug from the hydraulic block.

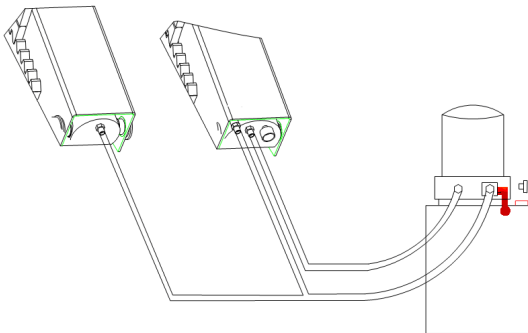

2. Connect the optional hand pump to hydraulic block at the point where the removable plug used to be fitted.

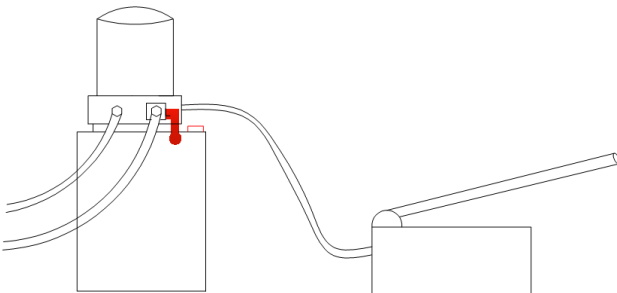

3. Press the handle of the optional hand pump to raise the platform to have the safety teeth unlocked. Then, pull up the safety teeth with steel rope to release the safety lock.

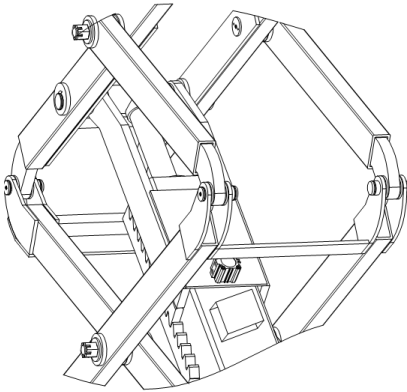

4. Screw loose the core of solenoid unloading valve fixed on the hydraulic block.

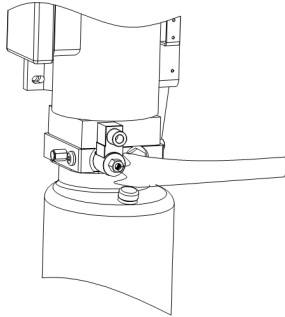

## TROUBLE SHOOTING

ATTENTION: If the trouble could not be fixed by yourself, please do not hesitate to contact us for help .We will offer our service at the earliest time we can. By the way, your troubles will be judged and solved much faster if you could provide us more details or pictures of the trouble.

TROUBLES	CAUSE	SOLUTION
Motor does not run and will not raise	The wire connection is loose.	Check and make a good connection.
	The motor is burnt	Replace it.
	The limit switch is damaged or the wire connection is loose.	Connect it or adjust or replace the limit switch.
Motor runs but will not raise	The motor run reversely.	Check the wire connection.
	Overflow valve is loose or jammed.	Clean or adjust it.
	The gear pump is damaged.	Replace it.
	Oil level is too low.	Add oil.
	The oil hose became loose or dropped off.	Tighten it.
	The cushion valve became loose or jammed.	Clean or adjusts it.
Platforms go down slowly after being raised	The oil hose leaks.	Check or replace it.
	The oil cylinder is not tightened.	Replace the seal.
	The single valve leaks.	Clean or replace it.
	The overflow valve leaks.	Clean or replace it.
	Electrical unloading valve leaks.	Clean or replace it.
Raising too slow	The oil filter is jammed.	Clean or replace it.
	Oil level is too low.	Add oil.
	The overflow valve is not adjusted to the right position.	Adjust it.
	The hydraulic oil is too hot (above 45°).	Change the oil.
	The seal of the cylinder is abraded.	Replace the seal.
Lowering too slow	The throttle valve jammed.	Clean or replace.
	The hydraulic oil is dirty.	Change the oil.
	The anti-surge valve jammed.	Clean it.
	The oil hose jammed.	Replace it.

## MAINTENANCE

Easy and low cost routine maintenance can ensure the lift work normally and safely. Following are requirements for routine maintenance. You may choose the frequency of routine maintenance by consulting your lift's working conditions and time.

The following parts need to be lubricated.

S/N	Description
1	Pin shaft
2	Pin shaft B
3	Rotor shaft
4	Rotor shaft
5	Pin shaft B
6	Shaft
7	Shaft

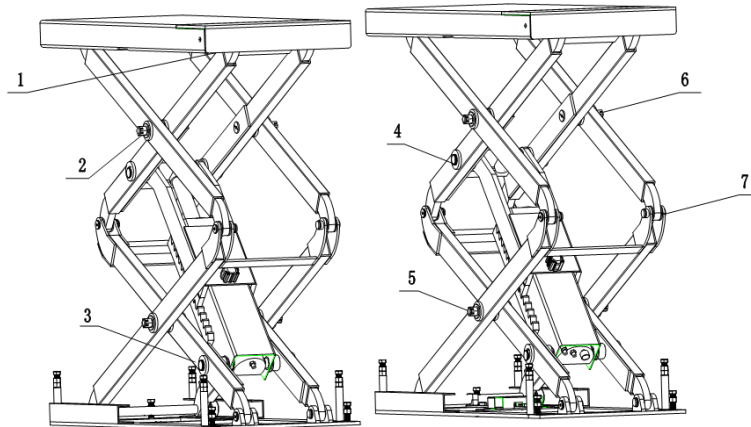

### 6.1. Daily checking items before operation

The user must perform daily check. Daily check of safety system is very important – the discovery of device failure before action could save your time and prevent you from great loss, injury or casualty.

- Check whether oil hose well connected. No leakage is allowed.
- Check the electric connections .Make sure all connections are in good condition.
- Check whether the expansion bolts well anchored.
- Check if safety teeth and safety block matched well or not.

### 6.2. Weekly checking items

- Check the flexibility of moving parts.
- Check the working conditions of safety parts.
- Check the amount of oil left in the oil tank. Oil is enough if the carriage can be raised to highest position. Otherwise, oil is insufficient.
- Check whether the expansion bolts well anchored.

### 6.3. Monthly checking items

- Check whether the expansion bolts well anchored.
- Check the tightness of the hydraulic system and screw firm the joints if it leaks.
- Check the lubrication and abrasion circumstance of moving parts.

### 6.4. Yearly checking items

- Empty the oil tank and check the quality of hydraulic oil.
- Wash and clean the oil filter.

**If users strictly follow the above maintenance requirements, the lift will keep in a good working condition and meanwhile accidents could be avoided to a large extent.**

## ANNEX

### Annex 1, Packing List of the whole lift

1	Scissor lift	FL-8802-0	Assembly	1
2	Expansion bolt	M16*120	Standard	8
3	Control unit		Assembly	1

### Annex2, Overall diagram

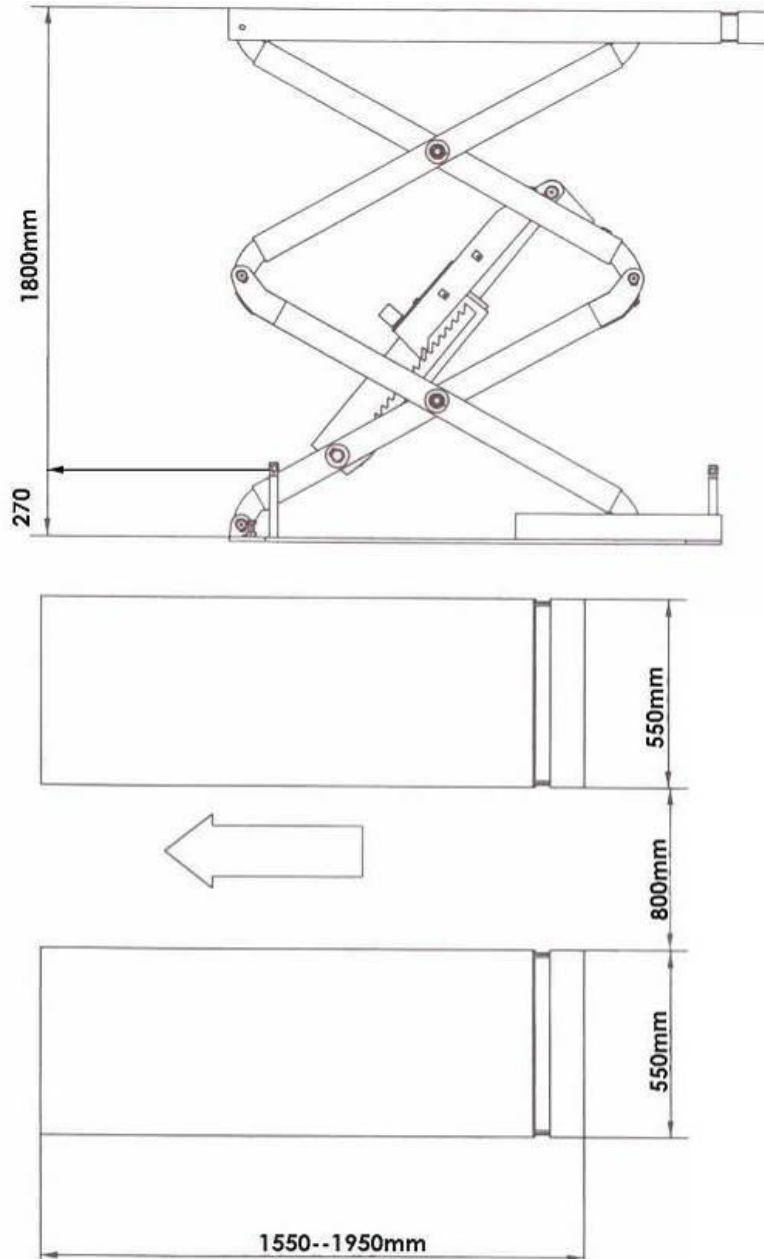



Annex3, Floor plan

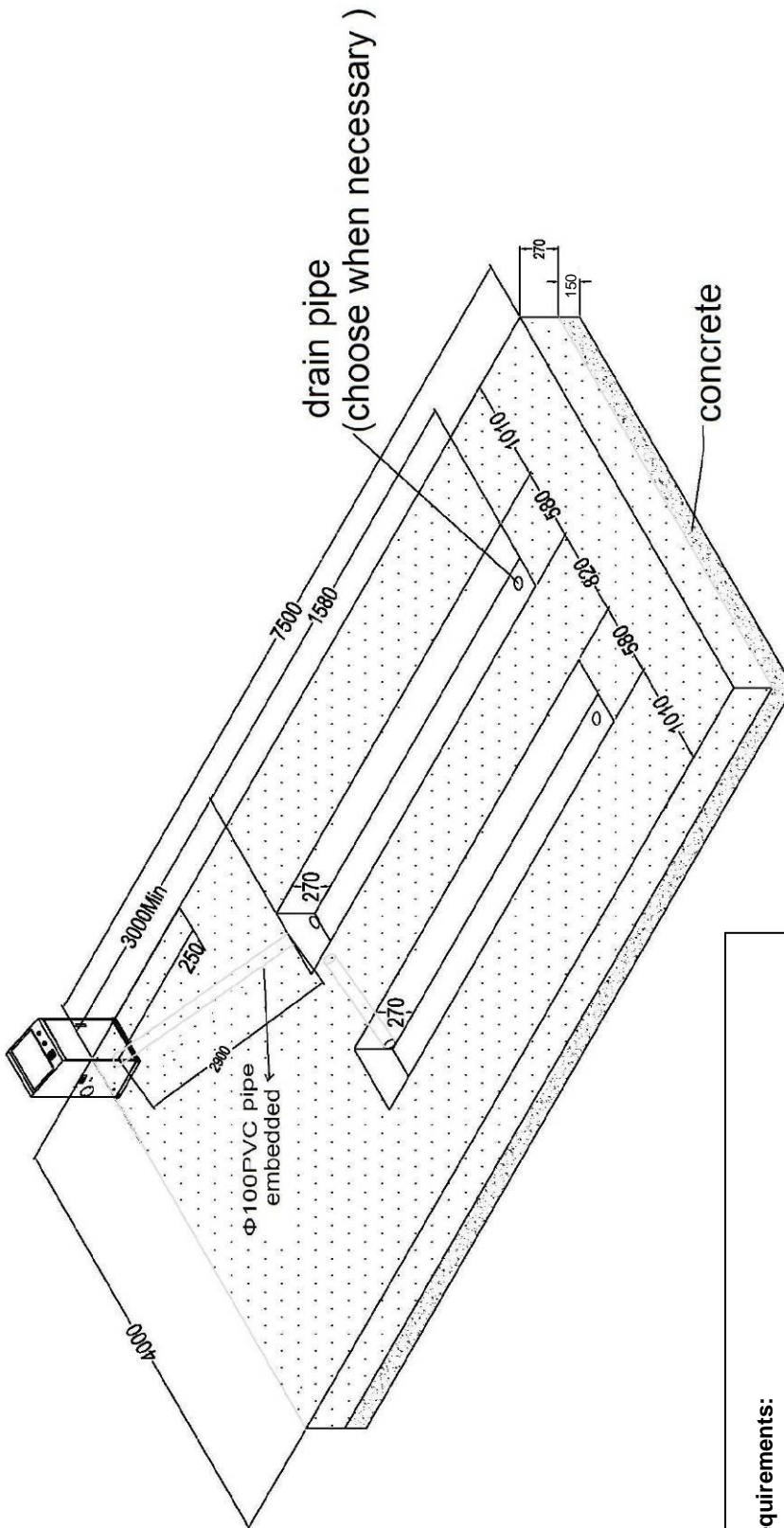

- Concrete requirements:**
- the concrete should be „C20/25“ according to DIN 1045-2 (previous name: DIN 1045 concrete B25)
  - Ground must be level and flatness less than 5 mm
  - new poured concrete must be for at least 28 days harden
- Other requirements:**
- the surrounding soil must be suitable for the load, no sandy soil etc.
  - reinforcements are not required for the proper use of the lift, but are recommended
  - in case of doubt, the foundation should be determined and tested by a structural engineer

Annex 4, Diagram for oil hose connection

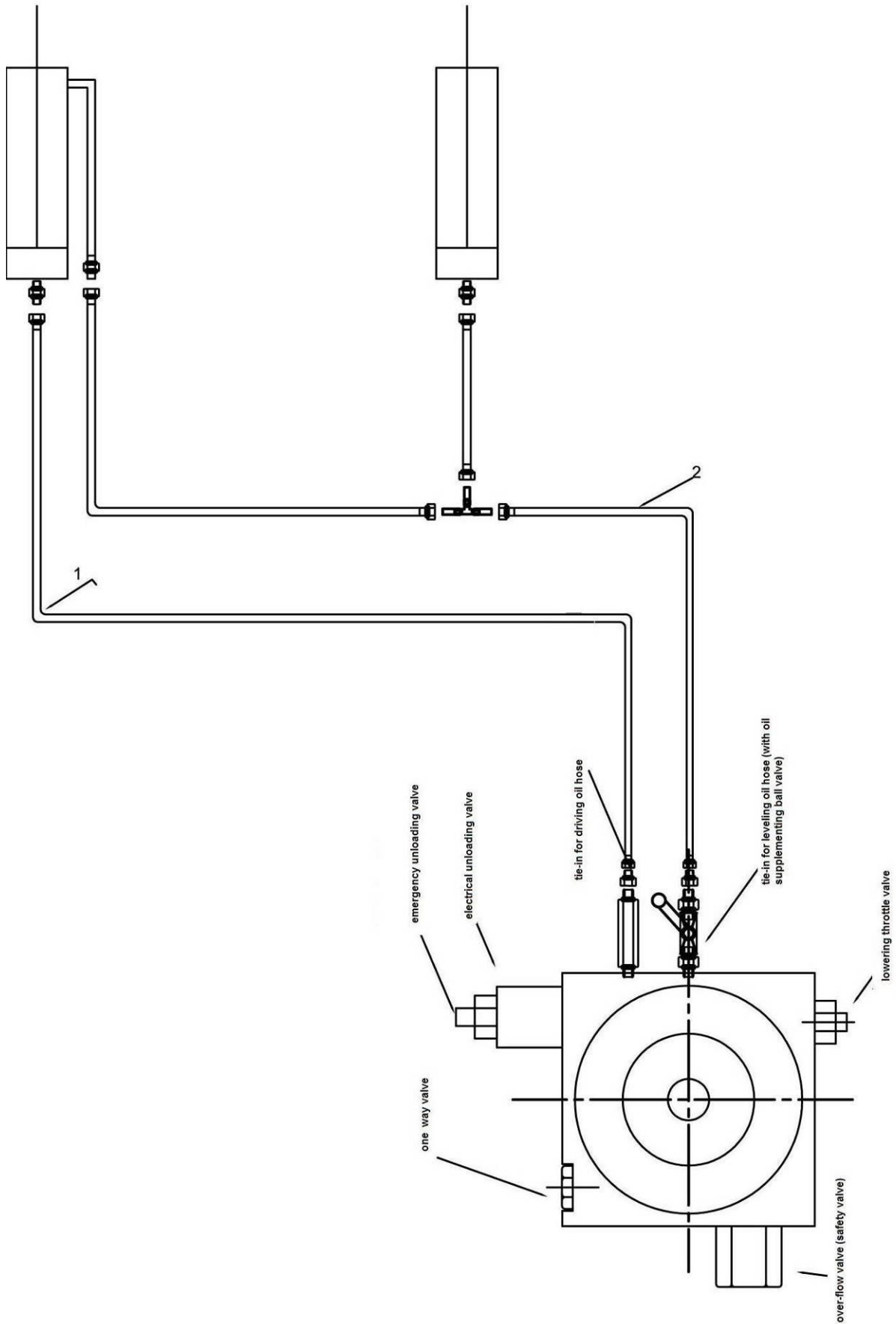

**Annex 5, Hydraulic working system  
Manual leveling**

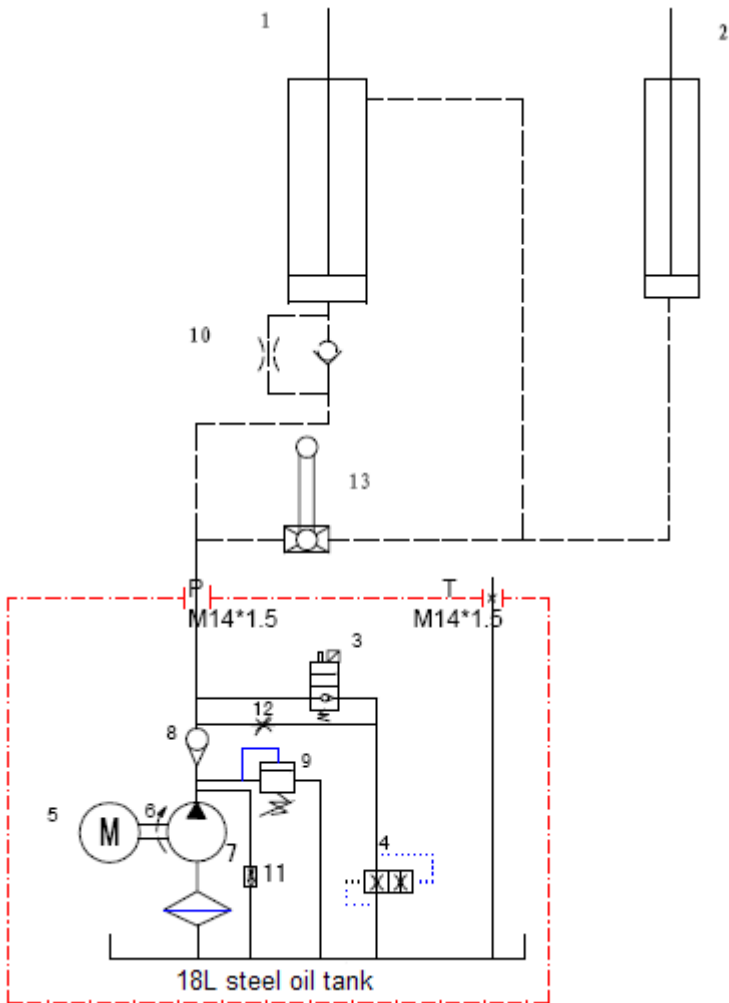

1. Drive oil cylinder
2. Oil cylinder
3. Solenoid valve (use manually or electrically)
4. Lowering throttle valve
5. Motor
6. Coupling
7. Gear pump
8. Single-way valve
9. Over-flow valve
10. Anti-surge valve
11. Cushion valve
12. Emergent unloading valve
13. Oil supplementing valve

**Solenoid valve  
(use manually or electrically)**

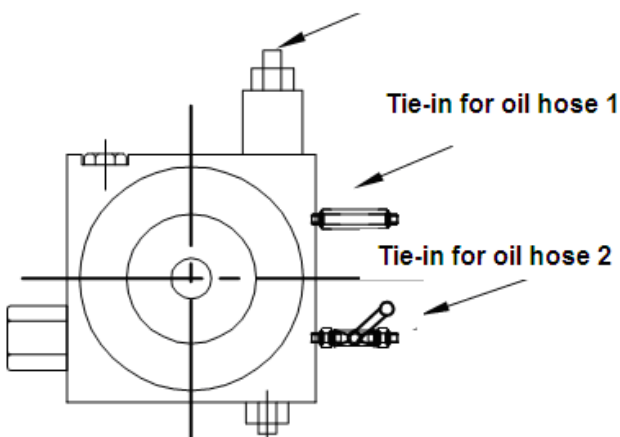

Annex6, Wiring diagram

Single phase

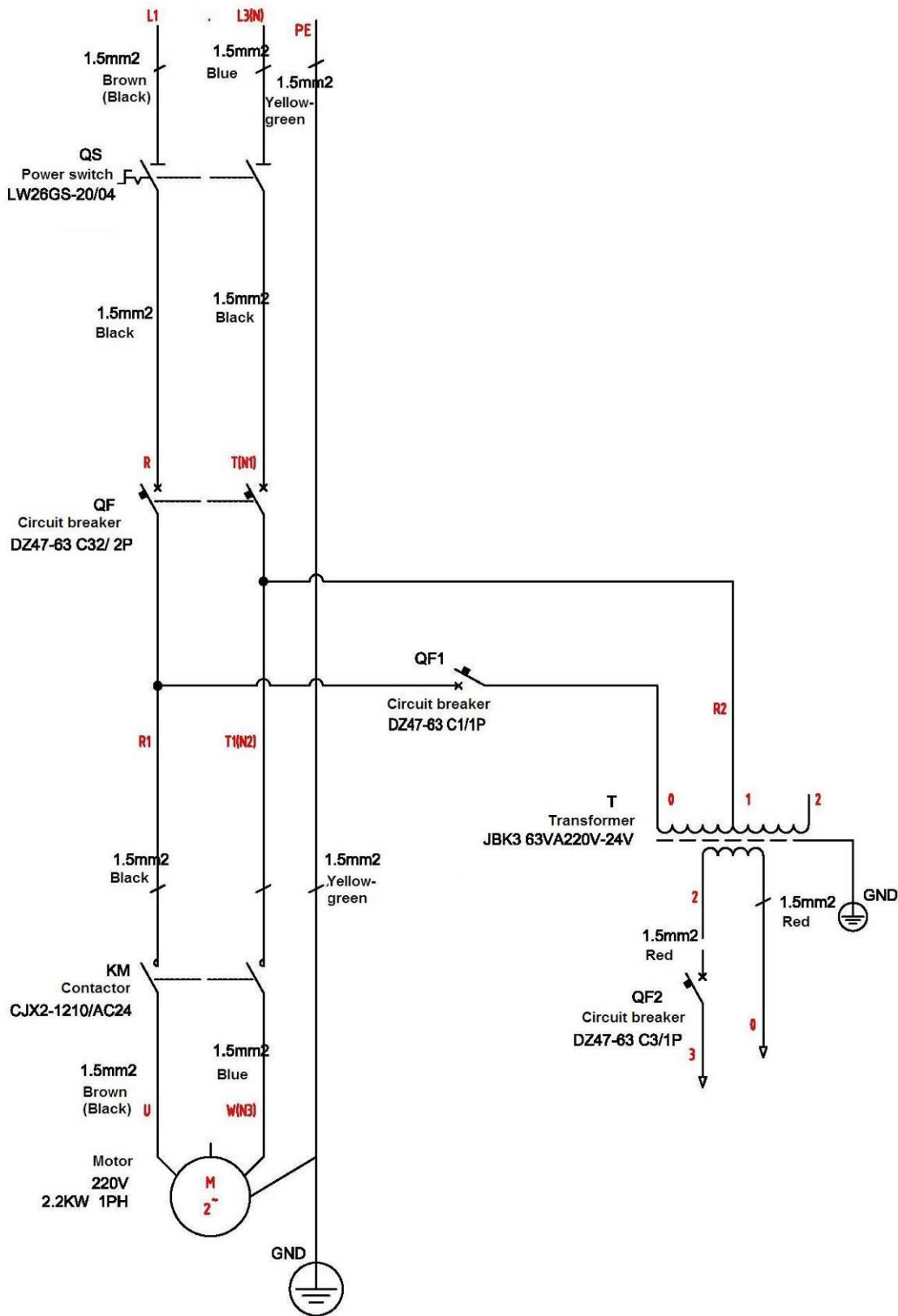

Three phase

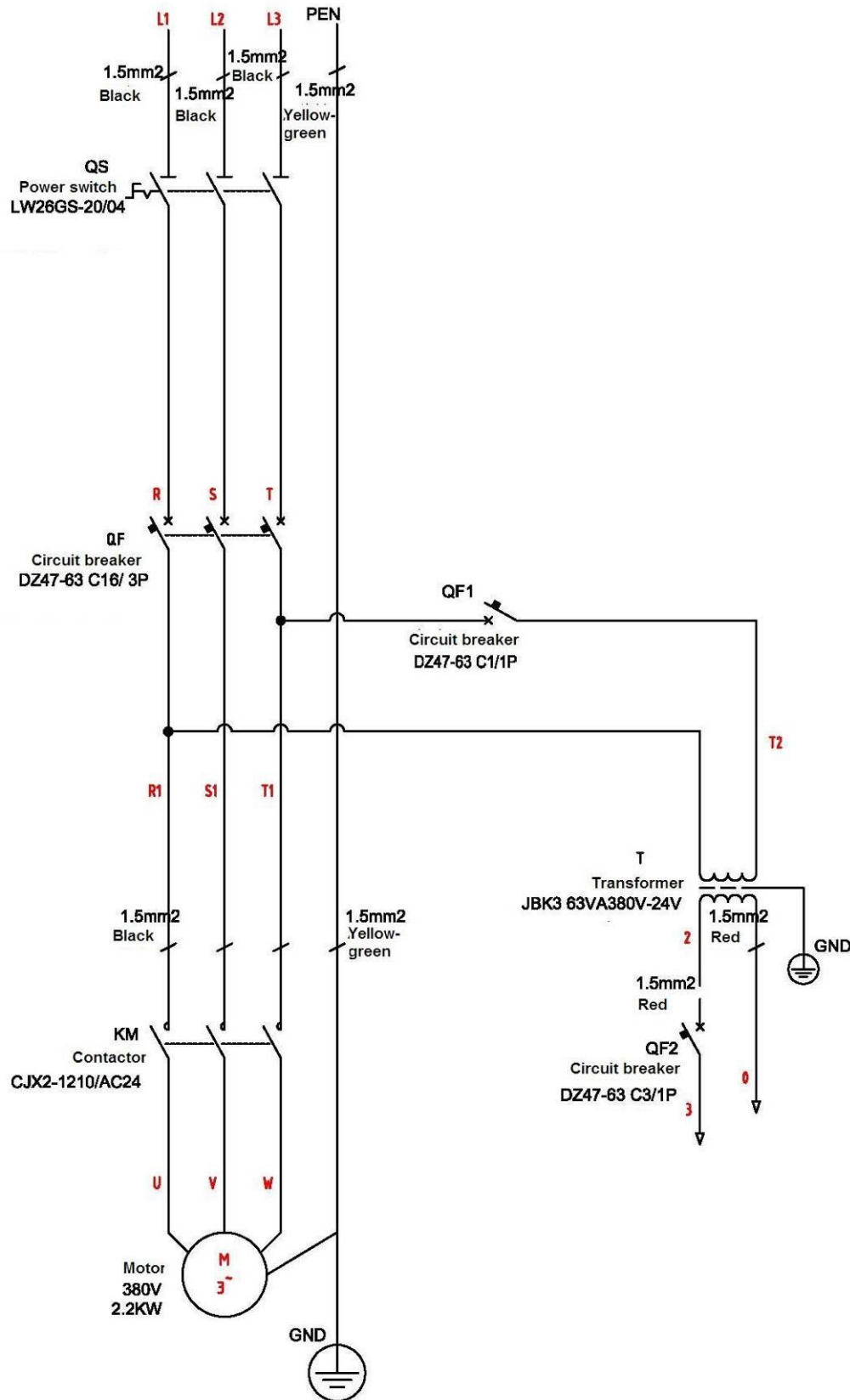

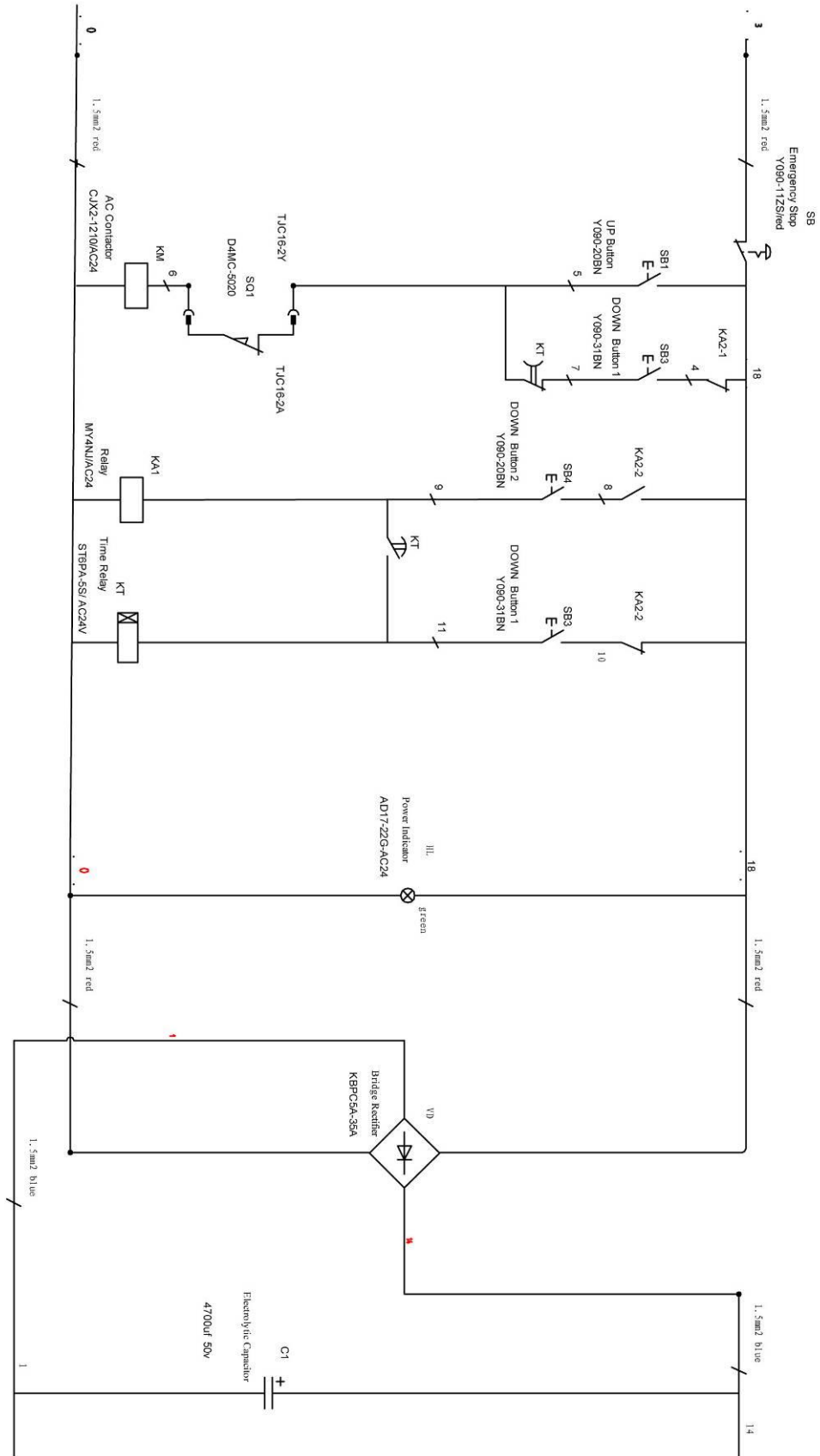

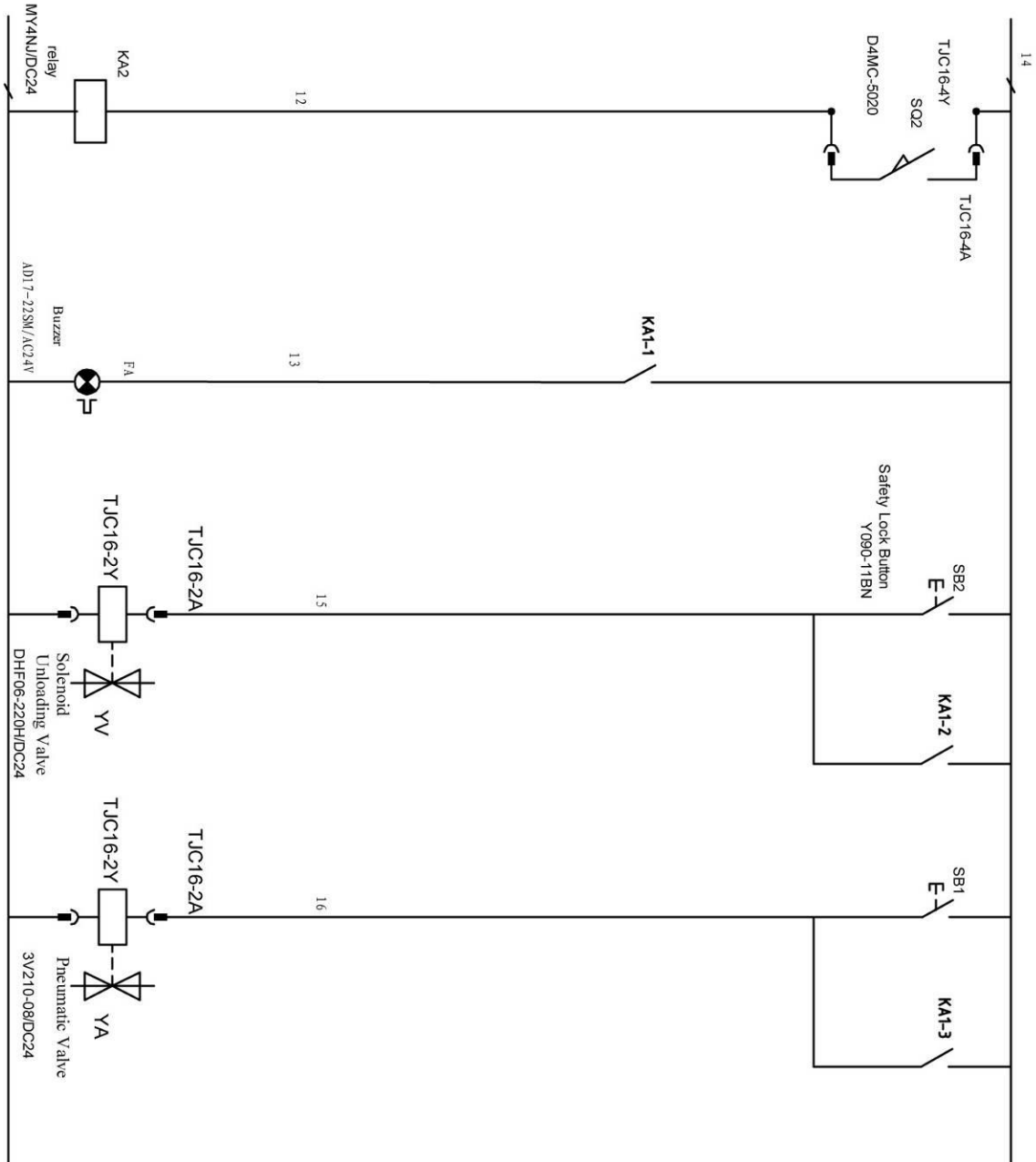

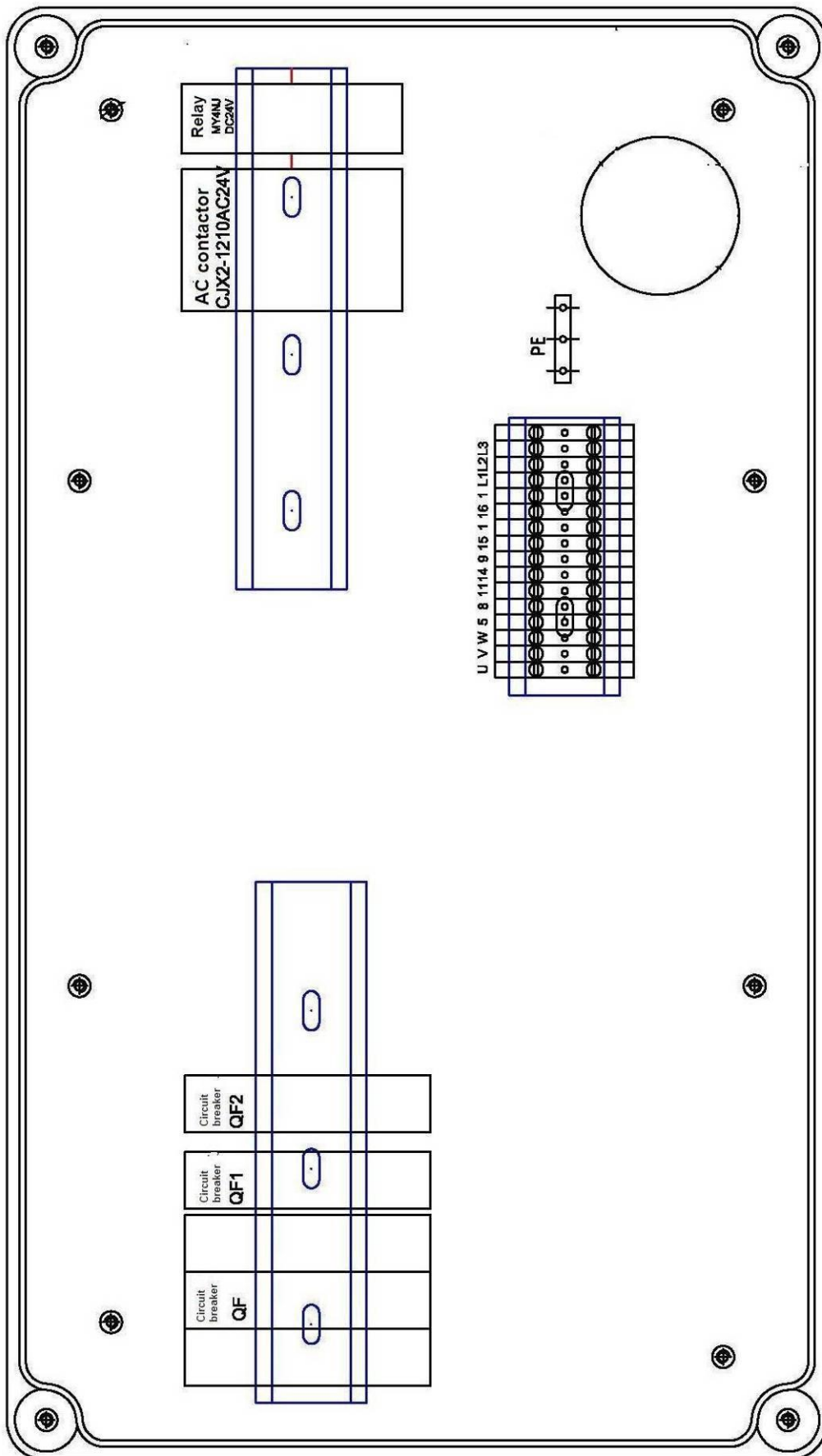



**Annex7, Diagram for air supply connection**

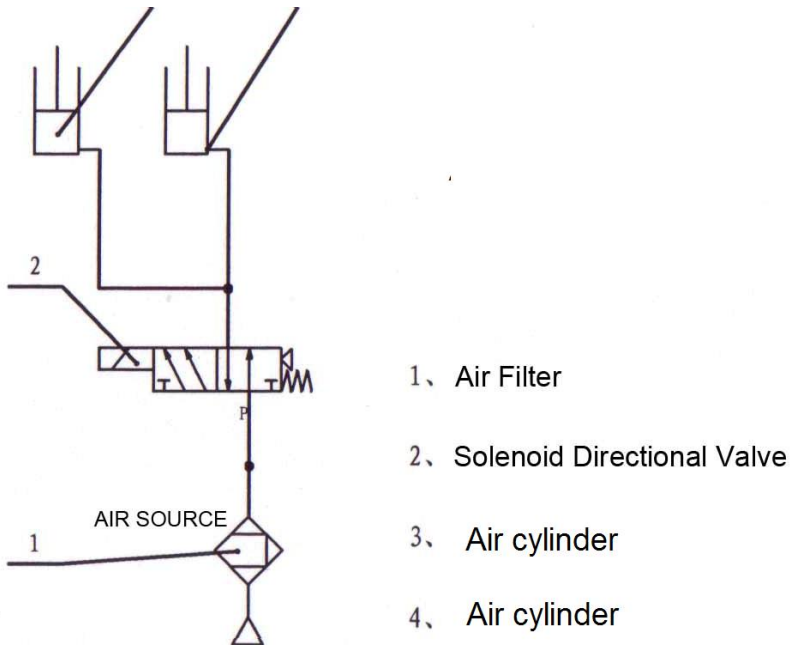

**Annex 8, Separated drawings for the lift**

**For the pump:**

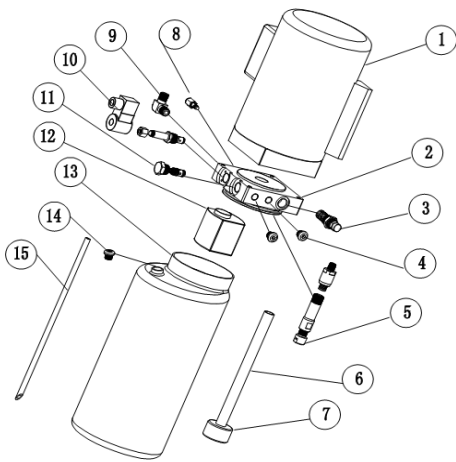

S/N	DESCRIPTION	QTY
1	Motor	1
2	Hydraulic block	1
3	Overflow valve	1
4	Fitting	2
5	Cushion valve	1
6	Absorbing oil hose	1
7	Oil filter	1
8	Throttle valve	1
9	Oil hose tie-in	1
10	Electrical unloading valve	1
11	One-way valve	1
12	Gear pump	1
13	Oil tank	1
14	Oil tank cover	1
15	Oil back hose	1

For mechanical assembly

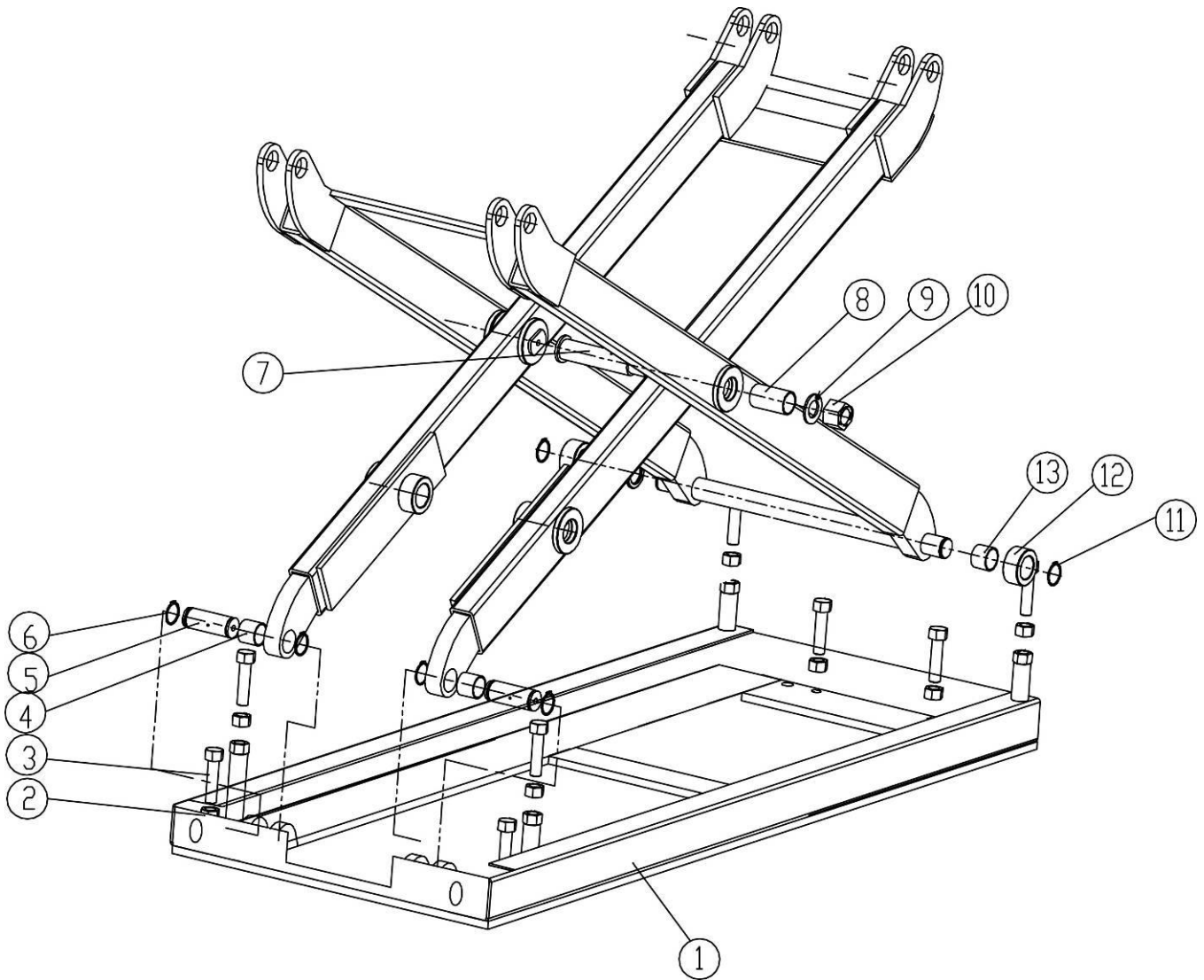

S/N	Material#	Name	Spec.	Qty	Property	Note
1		Base assembly	FL-8802-A1-B1	1	Welded	
2		Hex nut	M16	8	Standard	
3		Bolt	M16X50	4	Standard	
4		Bearing	3025	2	Standard	
5		Shaft A	FL-8802-A2	2	45#	
6		Circlip	Φ30	4	Standard	
7		Shaft B	FL-8802-A5-B5	2	45#	
8		Bearing	3055	2	Standard	
9		Flat washer	Φ24	2	Q235A	
10		Slotted nut	M24*3	2	Standard	
11		Circlip	Φ30	2	Standard	
12		Roller	FL-8802-A5-B2-C4	2	Nylon	
13		Bearing	3025	2	Standard	

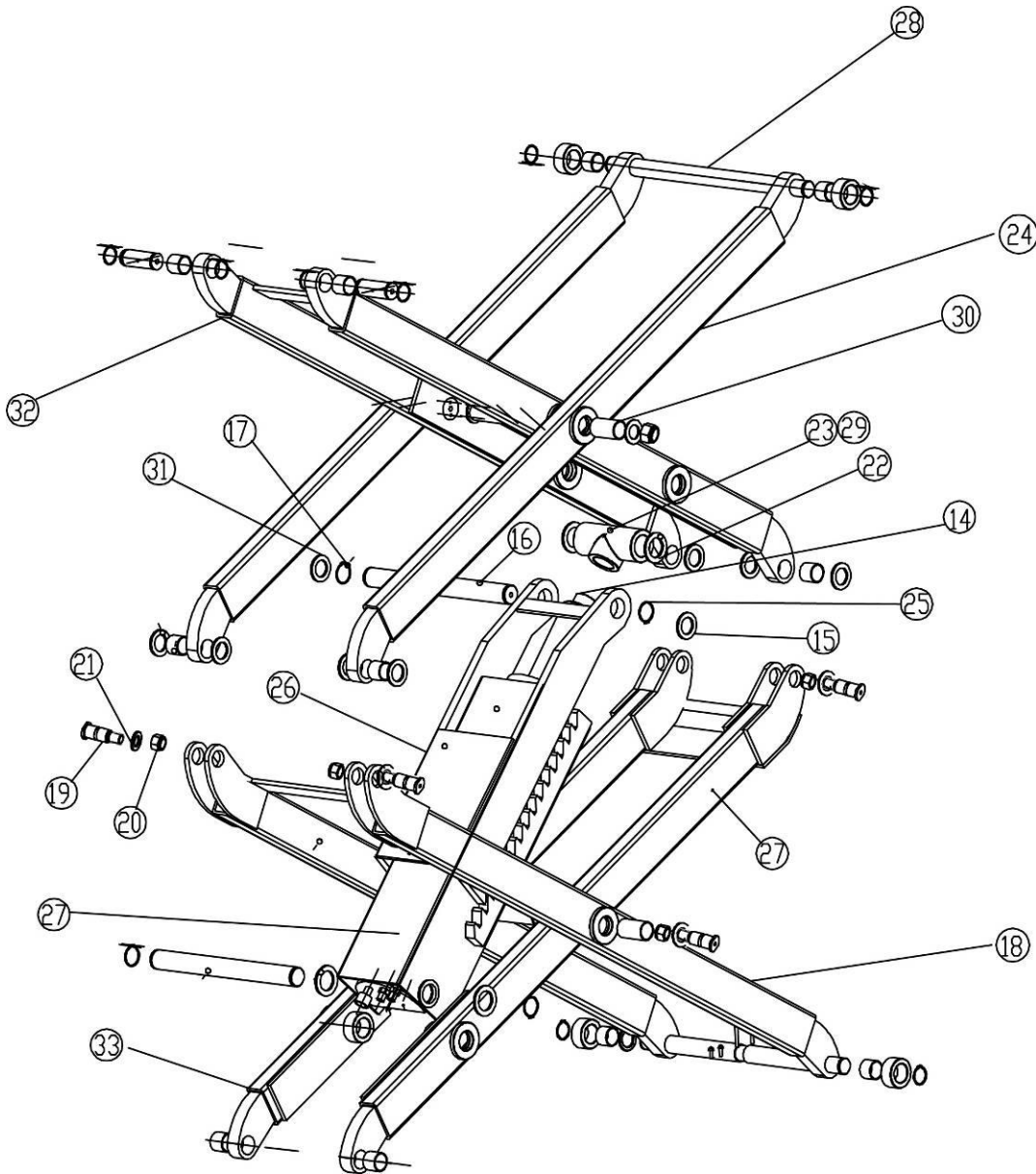

S/N	Material#	Name	Spec.	Qty	Property	Note
14		Oil cylinder	FL-8802-A4-B1	1		
15		Spacer	FL-8802-A3-B4	2	Q235	
16		Oil cylinder shaft	FL-8802-A3-B1	1	45	
17		Circlip	Ø35	2	GB/T894.1	
18		Movable bracket A	FL-8802-A5-B2	1		
19		Shaft A	FL-8802-A2	4	45	
20		Slotted nut	M24*3	8	GB/T894.1	
21		Thin spacer	FL-8802-A5-B10	4	Q235	
22		Thick spacer	FL-8802-A5-B9	6	Q235	
23		Bearing	3028	4	SF-1	
24		Movable bracket A	FL-8802-A5-B3	1		
25		Circlip	Ø35	2	GB/T894.1	
26		Air cylinder plate	FL-8802-A3-B5	1		
27		Cylinder sheath	FL-8802-A3-B3	1		
28		Oil cylinder shaft	FL-8802-A3-B1			

S/N	Material#	Name	Spec.	Qty	Property	Note
29		Oil cylinder connector	FL-8802-A3-B6	1		
30		Bearing	3550	2	SF-1	
31		Spacer	FL-8802-A3-B4	2		
32		Movable bracket D	FL-8802-A5-B4	1		
33		Movable bracket A	FL-8802-A5-B1	1		

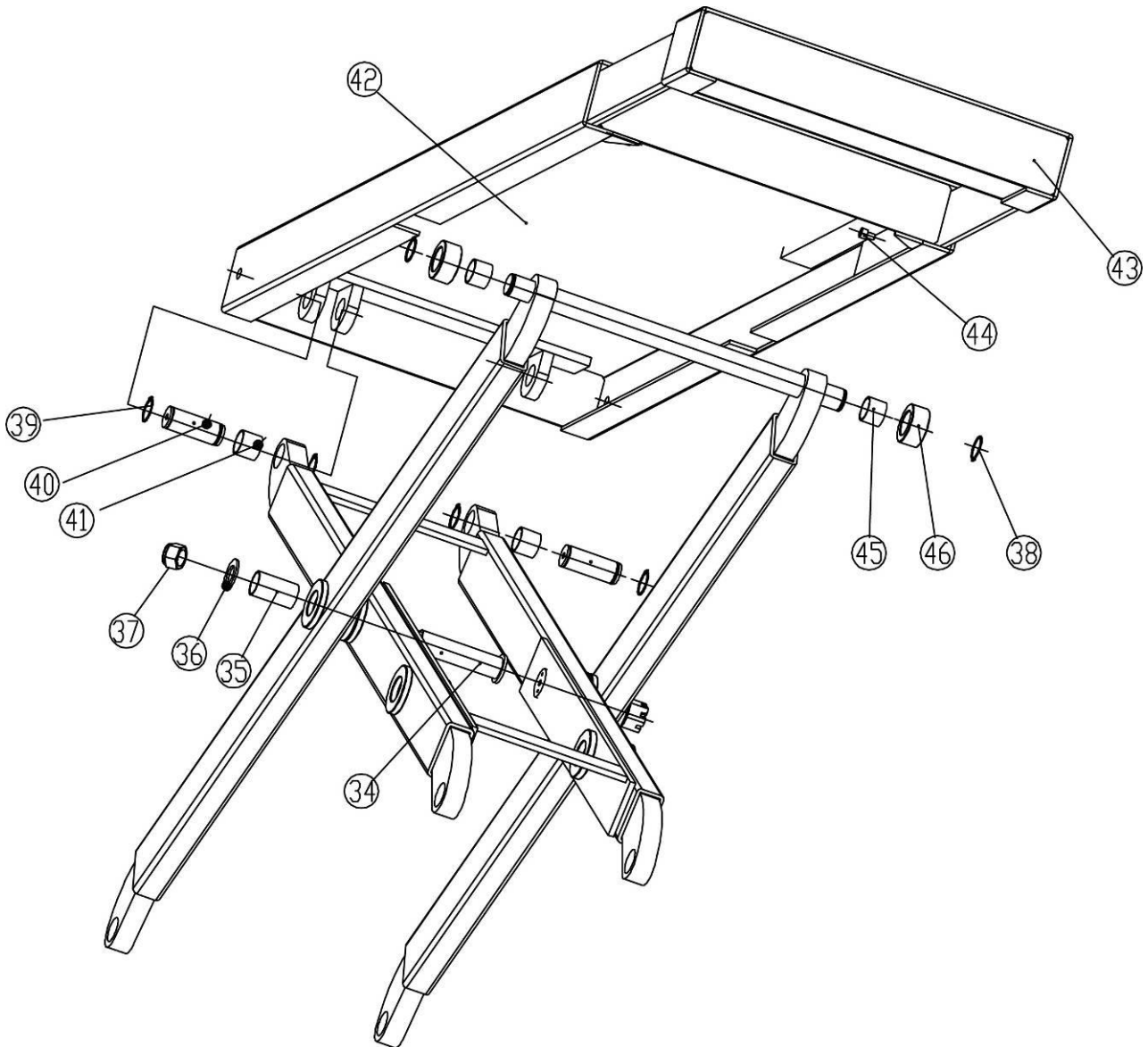

S/N	Material#	Name	Spec.	Qty	Property	Note
34		Shaft B	FL-8802-A5-B5	2	45	
35		Bearing	3055	2	SF-1	
36		Flat washer	Ø24	2	GB/T95	
37		Hex slotted nut	M24*3	2	GB/T6178	
38		Cotter pin	Ø2.5	2	GB/T91	
39		Circlip	Ø30	4	GB/T894.1	
40		Shaft	FL-8802-A2	2	45	
41		Bearing	3028	2	SF-1	
42		Runway	FL-8802-A6-B2	1		
43		Runway extension	FL-8802-A6-B3	1		

44		Inside hex cylinder screw	M8X12	2	GB/T70	
45		Bearing	3025	2	SF-1	
46		Roller	FL-8802-A5-B2-C4	2	Nylon	

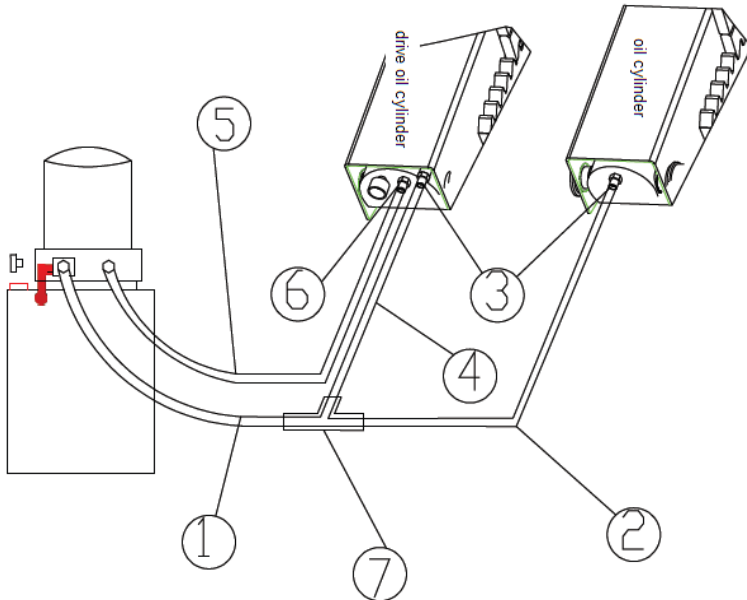

S/N	Material#	Name	Spec.	Qty	Property	Note
1		Oil hose	FL-8802-A3-B8	1	Assembly	3,8M in length, with a straight connector at one end and the a being connector at the other
2		Oil hose	FL-8802-A3-B8	1	Assembly	1.9M in length, with two straight connector at both ends
3		Connector B	EE-6501-A4-B16	2		
4		Oil hose	FL-8802-A3-B8	1	Assembly	0.35M in length, with two straight connector at both ends
5		Oil hose	FL-8802-A3-B8	1	Assembly	4,2M in length, with a straight connector at one end and the a being connector at the other
6		Throttle valve	6501-A4-B15	1		
7		Three-way connector	6603B-A9-B7	1	45#	

**Annex 9, Spare parts list**

**Spare parts for the mechanical part**

S/N	Material#	Name	Spec.	Qty	Property	Note
1		Retaining block B for limit switch	FL-8802-A1-B7	1	Q235	
2		Up fixing block	FL-8802-A1-B8	1	Q235	
3		Down fixing block	FL-8802-A1-B9	1	Q235	
4		Drawbar	FL-8802-A1-B6	1	Q235	
5		Retaining block A for limit switch	EE-6501-A1-B3	1	Q235	
6		Protection cover	FL-8802-A1-B2	1	Q235	

7		Installation plate for limit switch	FL-8802-A1-B10	1	Q235A	
8		Limit block	FL-8802-A1-B4	2	Q235A	
9		Spacer	FL-8802-A3-B4	2	Q235	
10		oil	Ø8	4	Standard	
11		Spacer	FL-8802-A3-B4	2	Q235A	
12		Seal ring	KGD120*95*22.4*6.35	1		
13		Y-shape seal ring	67*77*6	1		
14		O-shape seal ring	109*5.3	1		
15		O-shape seal ring	118*3.55	1		
16		O-shape seal ring	53*3.55	1		
17		Seal ring	KGD100*75*22.4*6.35	1		
18		O-shape seal ring	38.7*3.55	1		
19		O-shape seal ring	92.5*3.55	1		

**Spare parts for the electrical system**

S/N	Material #	Name	Spec.	Qty	Unit	Pic
1		Power switch	LW26GS-20/04	Pcs	1	
2		Button	Y090	Pcs	3	
3		Power indicator	AD17-22G-AC24	Pcs	1	
4		Transformer	JBK-63VA220V-24V	Pcs	1	Same as item 7
5		Transformer	JBK-63VA230V-24V	Pcs	1	Same as item 7
6		Transformer	JBK-63VA240V-24V	Pcs	1	Same as item 7
7		Transformer	JBK-63VA380V-24V	Pcs	1	
8		Transformer	JBK-63VA400V-24V	Pcs	1	Same as item 7
9		Transformer	JBK-63VA415V-24V	Pcs	1	Same as item 7
10		AC contactor	CJX2-1210/AC24	Pcs	1	
11		Circuit breaker	DZ47-63 C16 /3P	Pcs	1	

S/N	Material #	Name	Spec.	Qty	Unit	Pic
12		Circuit breaker	DZ47-63 C32 /2P	Pcs	1	
13		Circuit breaker	DZ47-63 C3 /1P	Pcs	1	
14		Pneumatic solenoid valve	3V210-08/DC24	Pcs	1	
15		Limit switch	ME8104	Pcs	1	
16		Option switch	Y90-11x	Pcs	1	
17		Bridge rectifier	KBPC5A-35A	Pcs	1	
18		Capacitor	4700UF/50V	Pcs	1	
19		Control box	460*260*135	Pcs	1	
20		Relay	MY4NJ/DC24	Pcs	1	
21		Relay holder	PYF14AE	Pcs	1	
22		Limits switch	8108 (TZ8108)	Pcs	1	



**Space for notes:**









**Safety review pursuant to UVV type**

Safety inspection before commissioning/ regular checks/ extraordinary

(Mark off those that do not apply)

Inspection	Good shape	defective	Re-inspection	Notes
Warning labels/ signs				
Name plate/ ID				
Limit switch function				
Condition of rubber plates				
Function of carrier arm locks				
Supporting structure (cracks etc.)				
Function of safety latches				
All screws tight				
Condition of steel cables				
Condition of covers				
Condition of chain				
Condition of cable pulleys				
Condition of hydraulic lines				
Fluid level of hydraulic unit				
Hydraulic system seals				
Condition of the piston rod				
Condition of electronics				
Function test of the lift				
Foundation condition (cracks)				
Lift Slides/guides in the lift column				
Other				
(Check the appropriate box, if re-inspection is necessary mark that box as well!)				

Inspector (Name, Address): .....

Inspected on: .....

**Inspection result:**

- Commissioning/ use possible. Resolve issues by .....
- Commissioning/ use prohibited. Re-inspection necessary.
- No defects. Commissioning/ use possible.

Signature owner/ operator: .....

Signature inspector: .....



**Inspection findings**

Regular/ extraordinary inspection

On the date of ..... this lift was put through a regular/ extraordinary and thorough inspection. During this inspection these issues were/ were not found.

.....  
.....

Scope of the audit:

.....

Outstanding partial inspection:

.....

The use of this equipment is authorized and the machine and all features have been inspected .

Location/ Date	Inspectors signature
----------------	----------------------

**Operator or agent**

Taken notes of the defects ..... ..

Defect corrected .....  
Date Signature

**Verification** .....  
Date Signature

On the date of ..... this lift was put through re-inspection. During this inspection these issues were/ were not found.

The use of this equipment is authorized and the machine and all features have been inspected.

Location/ Date	Inspectors signature
----------------	----------------------



**Safety review pursuant to UVV type**

Safety inspection before commissioning/ regular checks/ extraordinary  
 (Mark off those that do not apply)

Inspection	Good shape	defective	Re-inspection	Notes
Warning labels/ signs				
Name plate/ ID				
Limit switch function				
Condition of rubber plates				
Function of carrier arm locks				
Supporting structure (cracks etc.)				
Function of safety latches				
All screws tight				
Condition of steel cables				
Condition of covers				
Condition of chain				
Condition of cable pulleys				
Condition of hydraulic lines				
Fluid level of hydraulic unit				
Hydraulic system seals				
Condition of the piston rod				
Condition of electronics				
Function test of the lift				
Foundation condition (cracks)				
Lift Slides/guides in the lift column				
Other				
(Check the appropriate box, if re-inspection is necessary mark that box as well!)				

Inspector (Name, Address): .....

Inspected on: .....

**Inspection result:**

- Commissioning/ use possible. Resolve issues by .....
- Commissioning/ use prohibited. Re-inspection necessary.
- No defects. Commissioning/ use possible.

Signature owner/ operator: .....

Signature inspector: .....

**Look at our videos!**  
**The perfect addition to the manual.**

**Just scan Qr-Code or copy this link:**



**Instruction video**

<http://www.youtube.com/watch?v=Gxpr-6XvsSc>



**Twinbusch**  
**App**



Official Youtube Channel  
Twin Busch Germany





The company

**Twin Busch GmbH | Amperestr. 1 | D-64625 Bensheim**

declares hereby, that the **scissor vehicle lift**

**TW S3-18 U | 3000 kg**

serial no.

in the configuration placed on the market by us, meets the relevant safety and health requirements, as required by the following EC directive(s) in it's/their current version(s).

EG-directive(s)

**2006/42/EC machines, 2009/42/EC low voltage**

Applied harmonized standards and regulations

**EN 1493:2010, EN 60204-1/A1:2009**

CE Certificate

**M6A 14 11 87411 011**  
**N8M 14 11 87411 012**

date of issue: 12.11.2014  
 place of issue: München  
 technical file no.: 646821 401301

Certification body

TÜV SÜD Product Service GmbH,  
 Ridlerstraße 65  
 80339 München, Germany  
 Notified Body Appointment No. 0123

**Any alteration to the equipment, improper use or installation void this declaration.**

Authorized person to compile technical documentation is: Michael Glade (adress as below)



**TWIN BUSCH GmbH**  
 Amperestr. 1 · 64625 Bensheim  
 Tel. 08251 / 70585-0 · Fax: 70585-29

Authorized signatory: Michael Glade  
 Bensheim, 24.04.15 Qualitätsmanagement

**Twin Busch GmbH | Amperestr. 1 | D-64625 Bensheim**  
**twinbusch.de | E-Mail: info@twinbusch.de | Tel.: +49 (0)6251-70585-0**



Twin Busch GmbH | Amperestraße 1 | D-64625 Bensheim  
Tel.: +49 (0) 6251-70585-0 | Fax: +49 (0) 6251-70585-29 | [info@twinbusch.de](mailto:info@twinbusch.de)