

TWS3-19E & TWS3-19E-G

INSTALLATION, OPERATION AND MAINTENANCE MANUAL



Always read these operating instructions carefully before operating the lift. Follow the instructions carefully.

Table of contents

- 1. General information1**
- 2. Identification of the instructions for use1**
- 3. Technical data.....1**
- 4. Modification of the product2**
- 5. Safety-related information2**
 - 5.1 Safety instructions.....3
 - 5.1 Warnings and symbols4
 - 5.2 Safety devices.....5
 - 5.3 Monitoring and testing the safety equipment.....5
- 6. Conformity of the product.....6**
- 7. Technical specification6**
 - 7.1 Machine description.....6
- 8. Assembly of the lifting platform7**
 - 8.1 Before installation7
 - 8.2 Ground conditions7
 - 8.3 Assembly instructions.....8
 - 8.4 Checkpoints according to the structure.....12
- 9. Commissioning13**
 - 9.1 Safety precautions.....13
 - 9.2 Description of the control unit (control box).....13
 - 9.3 Lifting and lowering process flow chart.....14
 - 9.4 Operating instructions.....14
- 10. Troubleshooting16**
- 11. Maintenance17**
 - 11.1 Daily inspection and maintenance of the lifting platform elements before use17
 - 11.2 Weekly inspection and maintenance of the lifting platform elements17
 - 11.3 Monthly inspection and maintenance of the lifting platform17
 - 11.4 Annual inspection and maintenance of the lifting platform elements.....17
- 12. Behavior in the event of an incident18**
- 13. Appendix19**
 - 13.1 Packing list for the lift.....19
 - 13.2 Dimensions of the lift19
 - 13.3 Foundation requirements and working area21



13.4 Hydraulic system23

13.5 Circuit diagrams24

13.6 Detailed drawing and parts description of the lift.....29

13.7 Spare parts list32

Further attachment:

- **EU Declaration of Conformity**

Important Information:

ASSEMBLY



You can find the assembly video for this lift on YouTube: <https://youtu.be/O1c9d8WmqxA> or scan the QR code.



PRODUCT PRESENTATION



You can find the product presentation video for this lift on YouTube: <https://youtu.be/uniXSgKlwj0> or scan the QR code.





TIPS & TRICKS



In the "Tips & Tricks" section we show you simple solutions to work even more efficiently with your TWIN BUSCH® products.

<https://www.twinbusch.co.uk/Tips-Tricks/:74.html>

24/7 Service Center:



Our **24/7 Self-Service Center** is a mobile website designed for self-diagnosis of issues with your Twin Busch lift. Here, we provide an extensive video collection covering a wide range of relevant topics for your Twin Busch lift, from fine-tuning and maintenance to component replacement.

With the **24/7 Self-Service Center**, you have a versatile tool at your disposal to learn how to independently maintain and repair your Twin Busch lift.

To access the site on your mobile device, please visit [twinbusch.com/qr](https://www.twinbusch.com/qr) or scan the QR code provided alongside.

For Twin Busch lifts shipped from mid-2020 onwards, you'll also find the QR code on a sticker attached to the control box.

1. General information

The **TW S3-19E / TW S3-19-E-G** double scissor lift has a lifting height of 1850 mm and a permissible load capacity of 3,000 kg. It is CE-certified by an authorised certification body. The ultra-flat design means that even low sports cars can be lifted with ease. Double hydraulic cylinders on each side and a tilt lever system ensure powerful lifting. It is also ideal for tyre services, bodywork and vehicle preparation.

Special features of the product:

- **1A Quality built with CE-Certificate**
- Manufactured in accordance to **ISO 9001**
- Acoustic Warning signal (foot protection)
- IR-System (Light beam constantly ensures both platforms remain synchronised)
- Electromagnetic safety release
- Hydraulic synchronisation
- Automatic safety-lock-release system
- No restricting crossbar
- Rocker arm system
- High quality solid construction
- Emergency lowering valve
- Comfortable and easy-to-use control panel

2. Identification of the instructions for use

Instruction manual **TWS3-19E & TWS3-19E-G**

of Twin Busch GmbH,
Ampèrestraße 1,
D-64625 Bensheim

Phone: +49 6251-70585-0
Telefax: +49 6251-70585-29
Internet: www.twinbusch.de
Email: info@twinbusch.de

Twin Busch UK Ltd.
9, Linnell Way
Telford Way Industrial Estate
NN16 8PS, Kettering (Northants)

Phone: +44 (0) 1536 522 960
Internet: www.twinbusch.co.uk
Email: info@twinbusch.co.uk

Status: -00, 26.06.24

File: TWS3-19E_TWS3-19E-G_DoubleScissorsLift_Manual_uk_00_20240626.pdf

3. Technical data

Power supply	230 V / 400 V
Fusing	C 16A
Lifting capacity CE	3,000 kg
Max. lifting height	1850 mm + rubber
Lifting/lowering time	45/30 sec
Net weight	960 kg
Hydraulic pressure	22-24 MPa
Oil volume	16 L

4. Modification of the product

Improper use, modifications, conversions and attachments of the lift and all its components that have not been agreed with the manufacturer are not permitted. The manufacturer accepts no liability for improper installation, operation or overloading. Improper use also invalidates the CE certification and the validity of the certificate. If you require any changes, please contact your dealer or the expert staff at Twin Busch GmbH beforehand.

5. Safety-related information

Read the operating instructions carefully before operating the lift. Keep the instructions in a safe place for future reference. Follow the instructions carefully to achieve the best performance from the machine and to avoid damage due to personal negligence.

Unpack all parts and use the packing list to check that all components are present.

Check all connections and components thoroughly for damage. The lift may only be put into operation if it is in a safe operating condition.

Only lift vehicles within the rated load. Do not attempt to lift vehicles with excessive weight.

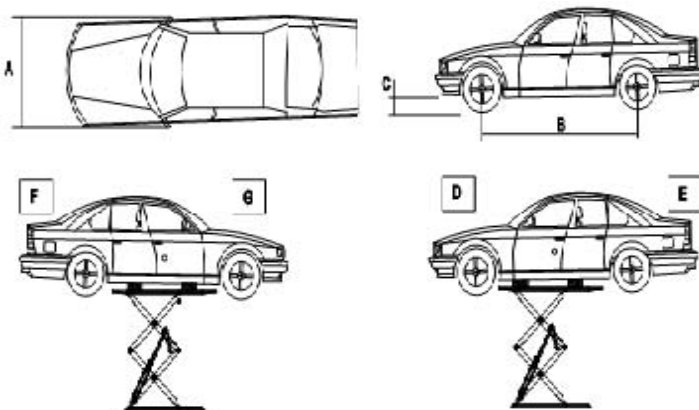

A (mm)	B (mm)	C (mm)	D (T)	E (T)	F (T)	G (T)
1900	2000	110	1.8	1.2	1.2	1.8

5.1 Safety instructions

- Do not install the lift on an asphalt surface.
- Read and understand the safety instructions before operating the lift.
- Do not leave the control unit under any circumstances when the lift is in motion.
- Keep hands and feet away from moving parts. When lowering, pay particular attention to your feet.
- The lifting platform may only be operated by trained personnel.
- Bystanders are not permitted in the vicinity of the lifting platform
- Wear suitable clothing.
- The area around the lifting platform should always be kept free of obstructions.
- The lift is designed for lifting the entire vehicle, which does not exceed the maximum authorised weight.
- Always ensure that all safety precautions have been taken before working near or under the vehicle.
- **Never remove safety-relevant components from the lift. Do not use the lift if safety-relevant components are missing or damaged.**
- Do not under any circumstances move the vehicle or remove heavy objects from the vehicle that could cause significant weight differences while the vehicle is on the lift.
- Always check the manoeuvrability of the lift to guarantee its performance. Ensure regular maintenance. If an irregularity occurs, stop working with the lift immediately and contact your dealer.
- Lower the lift completely when it is not in use. Do not forget to disconnect the power supply.
- If you do not use the lift for a longer period of time:
 - a.) Disconnect the lift from the power source.
 - b.) Empty the oil tank.
 - c.) Lubricate the moving parts with hydraulic oil.

Caution: To protect the environment, dispose of the oil that is no longer used in the prescribed manner.

5.1 Warnings and symbols

All warning labels are clearly visible on the lift to ensure that the user uses the equipment in a safe and appropriate manner.

The warning signs must be kept clean and replaced if they are damaged or missing. Please read the signs carefully and memorise their meaning for future operations.



Read instructions and safety instructions carefully before use!

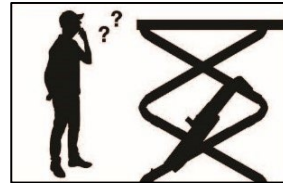

Operation of the lifting platform only by qualified personnel!



Repairs and maintenance only by qualified personnel, never put safety devices out of operation!



Risk of crushing when lifting or lowering!

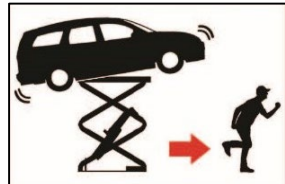

Escape routes always keep clear!



It is forbidden for persons to stand under the lifting platform (when lifting or lowering)!

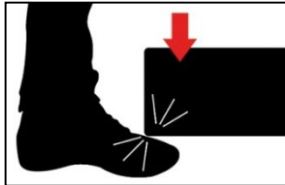

Pay attention to the lifting platforms and don't lower on to your feet! Crushing hazard!



Never attempt to load only one side of the lift!



Avoid shaking the vehicle.



No additional supports or interfering objects when lowering!



Do not exceed the specified load capacity! Distribute the vehicle weight over both platforms!



CAUTION!
Electrical voltage!

5.2 Safety devices

The lift is equipped with the following safety devices to ensure safe operation *):

- 24 V control unit
- Limit switch (max. height)
- Limit switch (switching height)
- Track guidance
- Mechanical safety catches

**) depending on the design and type of lift*

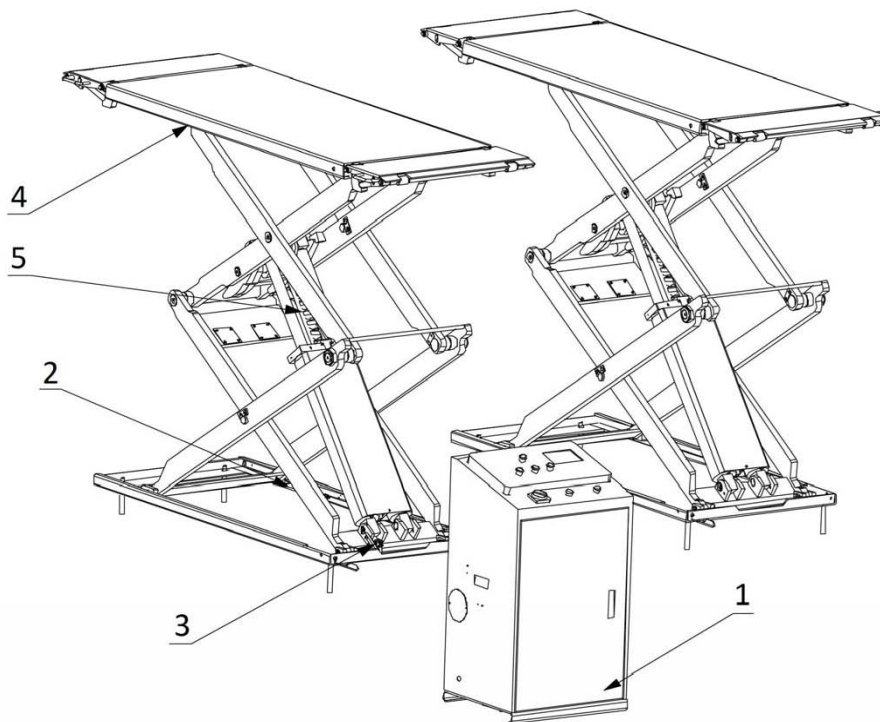

5.3 Monitoring and testing the safety equipment

- | | |
|-------------------------------------|--|
| 1) 24 V control unit | Low voltage for safe operation. |
| 2) Limit switch (max. height) | Limits the stroke at maximum lifting height. |
| 3) Limit switch (changeover height) | Stops the lowering movement at the safety height. Lower further with the "Down II" button, alarm signal sounds to alert people to stay away from the moving parts. |
| 4) Slider guide | Ensures safe guidance of the lifting platform. |
| 5) Mechanical safety catches | Lift is mechanically supported in the event of a hydraulic leak. |

6. Conformity of the product

The Double Scissors Lift TWS3-19E / TWS3-19E-G is CE-certified and is compliant with the Machinery Directive 2006/42/EC fulfilling the standards 1493:2022, EN 60204-1:2008 (look at: EU Declaration of Conformity, at the end of the user manual).

7. Technical specification

7.1 Machine description

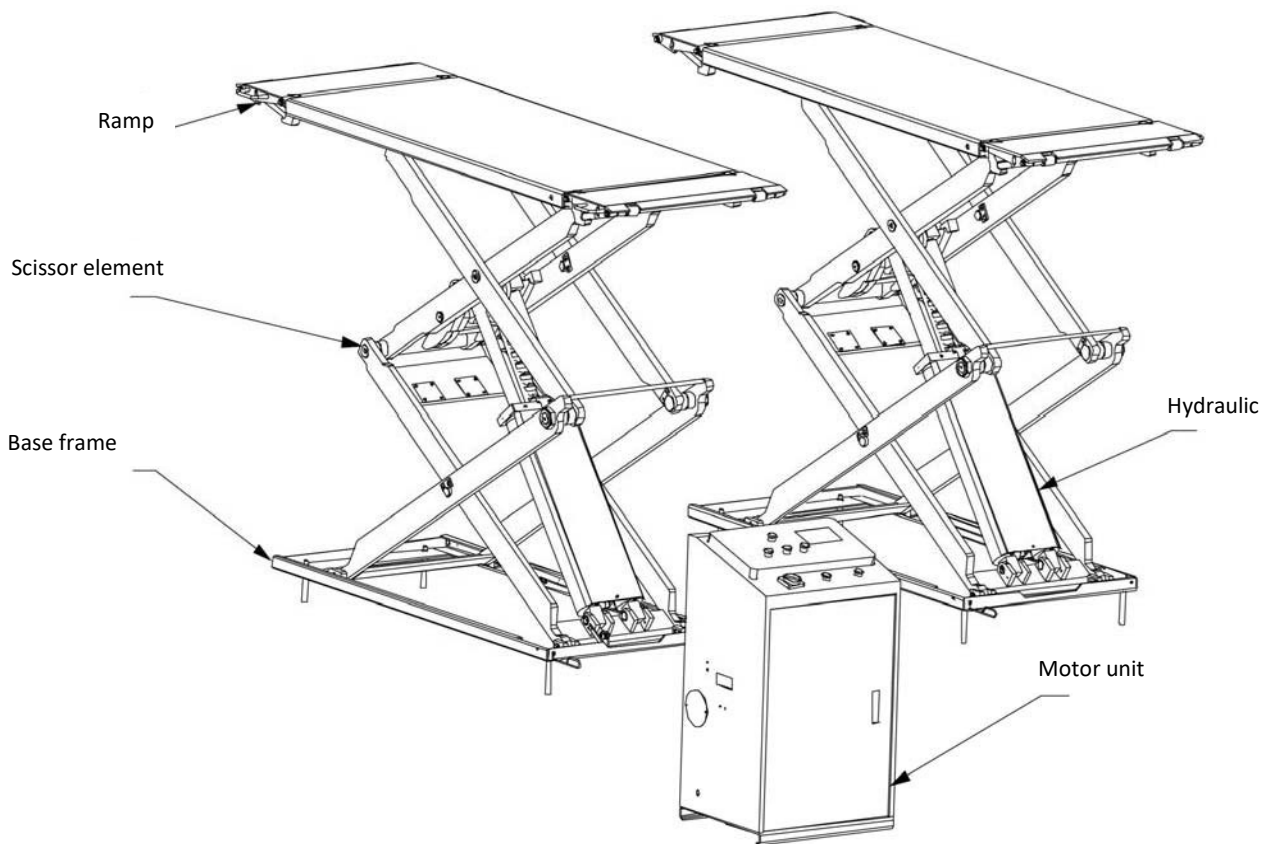

8. Assembly of the lifting platform

8.1 Before installation

Tools and equipment required:

- Electric drill (only required for permanent installation)
- Open-end spanner (SW 17-19 mm)
- Phillips screwdriver
- Spirit level
- Ratchet with nut (SW 24 mm)
- Lifting tool + 2 loops (e.g. forklift)
- Hammer
- Hydraulic oil HLP 32

8.1.1 Checklist (packing list):

Unpack all components of the lift and check that all components are complete using the **packing list** (see **appendix: Packing list**).

8.2 Ground conditions

Only use this lift on a surface that is stable, level, dry, non-slippery and capable of bearing the load. This lift must be installed on a solid concrete floor with a slope of no more than 0.5 %. Failure to do so may result in injury or even death. Do not install or use the lift on asphalt surfaces.

Detailed information can also be found in the corresponding foundation plan on our homepage at www.twinbusch.co.uk.

Note: If a new concrete floor is to be poured, it must cure for at least 28 days before a lifting platform can be installed.

8.3 Assembly instructions

- 1) Remove the packaging film in which the platform is wrapped. Look out for loosely packed parts. Read and understand the operating instructions before proceeding.
- 2) Lift the upper platform using a forklift truck or motorised crane and 2 lifting straps. Then lift the platform to the desired installation location (see the following illustrations). Remove the screws securing the lower platform and the pallet and move them to the installation location in the same way as the upper platform.

Caution: Before lifting, ensure that the hoses and cables are protected from damage. The platform must be secured during the lifting process.

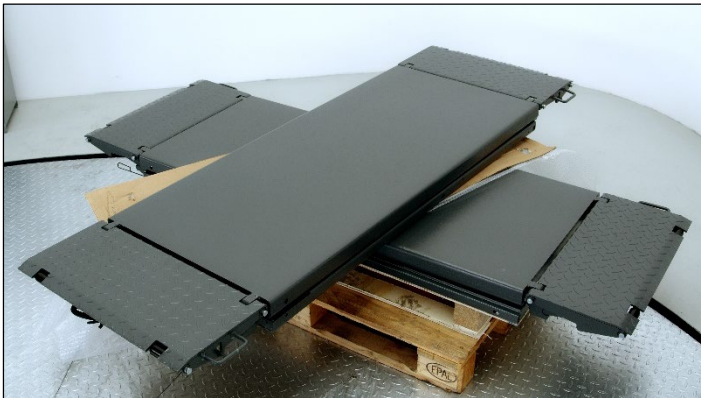

- 3) Connect the oil hoses. Ensure that all connections are securely tightened and securely seated. (see hydraulic circuit diagram)
If the hose fittings are not properly tightened, there will be a severe leak.
- 4) First connect the hydraulic hoses between the two runways. Then connect the two hydraulic hoses from the main platform to the connections remaining on the hydraulic block in the control cabinet. The hydraulic hoses are fed into the cabinet through the holes in the base of the control unit.

Caution: Do not contaminate the hydraulic components during connection.

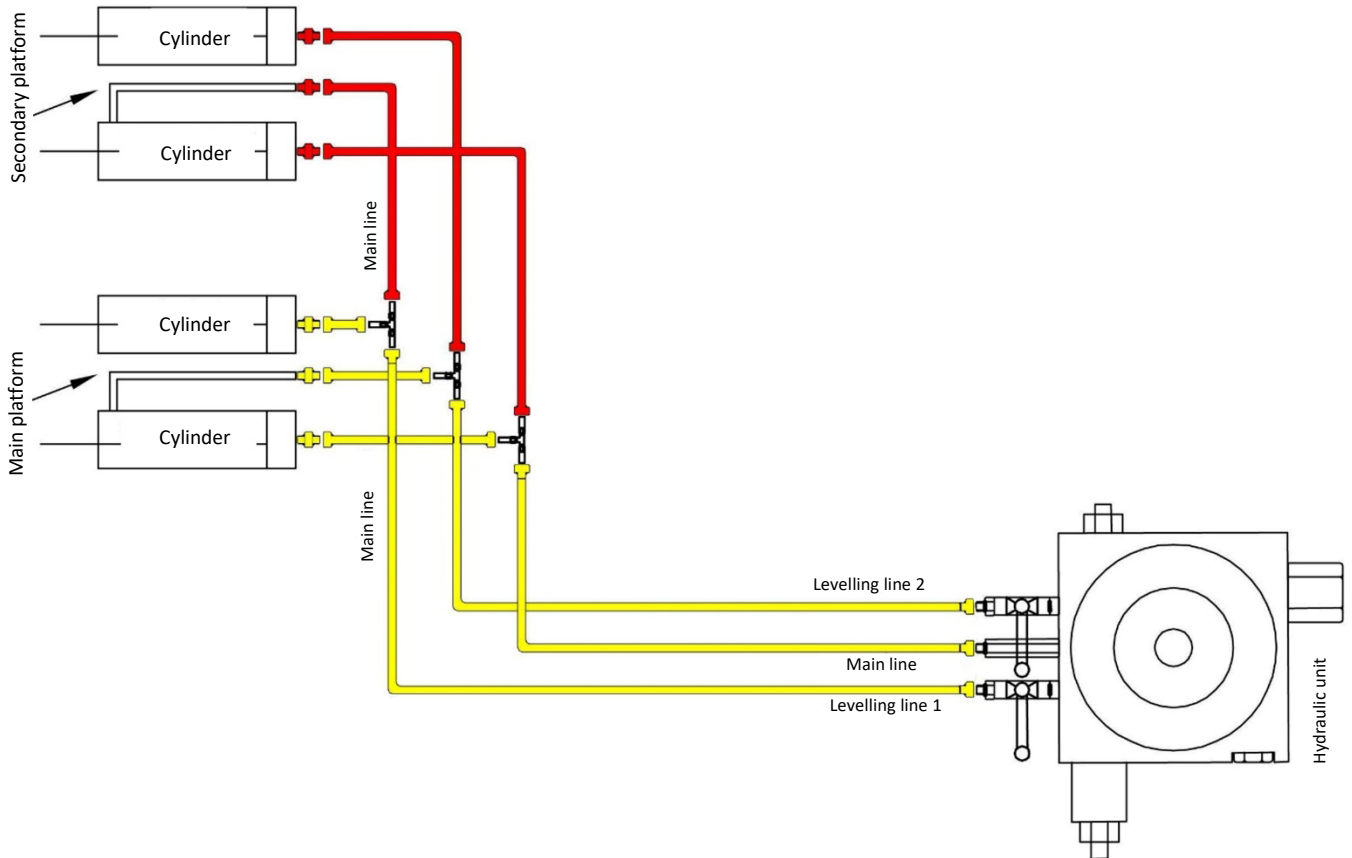

5) Connect the electrical system. This work must be carried out by a qualified electrical engineer!
 Requirements for the power supply cable at the installation site: At least 2.5 mm² wire for 3 Ph current and 4.0 mm² wire for 1 Ph current.

- When installing or repairing the electrical system, refer to the electronic circuit diagram in the appendix.
- Connect the cable plugs of the limit switches for raising and lowering.
- Connect the power supply cable to an external power supply.
 (If the lift does not lift with a three-phase power supply and the motor may turn in the wrong direction, swap the phases U, V in the control cabinet).
- The electromagnetic locking of the safety catches is connected as shown in the electrical circuit diagram.

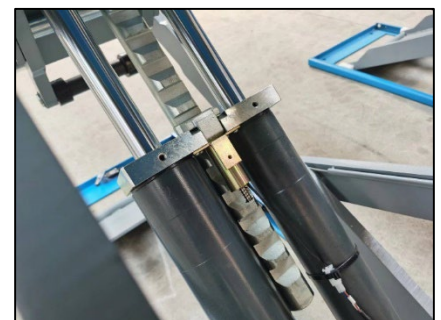
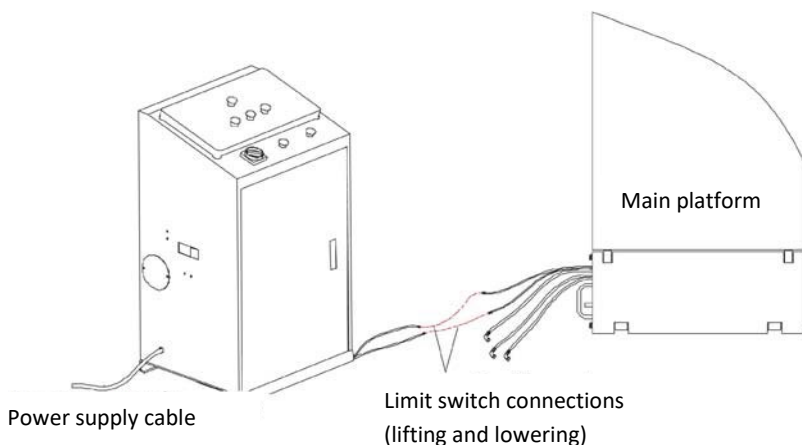
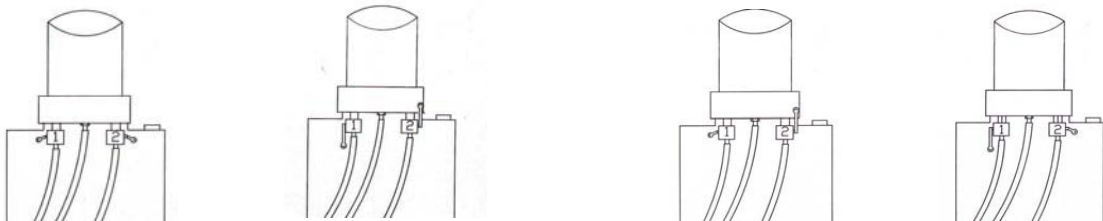

Figure: Locking the safety catches

- 6) Fill with hydraulic oil. **ONLY USE CLEAN AND FRESH OIL! DO NOT FILL THE TANK COMPLETELY! The lift must be fully lowered before hydraulic oil is changed or topped up!** Pour approx. 10 litres of hydraulic oil into the oil tank. The oil level must reach the volume mark on the tank.
Add more oil after several cycles until the lift has reached the maximum lifting height.
Note: It is recommended to use **HLP32 hydraulic oil**. Change the oil approx. 6 months after first use and then once a year.
- 7) Check the connection of the hydraulic and electrical system before levelling. Ensure that the oil hoses are connected correctly. Otherwise, oil cylinders may not work synchronously or may be damaged.

CAUTION: Level the platforms before connecting the limit switch for the maximum height. Otherwise, it may not be possible to raise the platforms to the highest position.

- 8) Read the operating instructions and familiarise yourself with the lift control by running the lift through a few cycles before levelling.
- 9) In addition, the operator must know exactly which levelling valve controls which platform. This can be judged by the way in which the oil hose was connected or by raising or lowering.
- 10) Open one of the levelling valves and press the UP button to fill the oil into the connected oil hose. Close the valve to stop the oil supply. Under normal operating conditions, both levelling valves are closed. When both valves are open, both platforms of the lift can still rise, but will not move upwards synchronously.



A: Both valves open

B: Both valves closed (normal operation)

C+D: One valve open, closed (levelling process)

- a) Open both levelling valves and press the UP button to bring both platforms to the highest positions. Repeat this step two or three times. (Note that this step can be time-consuming as there is air in the cylinders and the platforms are not loaded).
- b) Close both levelling valves as shown in drawing B. Press the UP button to check whether both platforms rise synchronously. (The platforms may not rise synchronously).
- c) If the synchronisation is not even, one platform may rise faster than the other. The user should first assess which levelling valve controls which platform and then open the valve that controls the slower rising platform to add oil to the oil hose. Press the UP button to bring both platforms to the same height. (The other valve must be closed.)
- d) Close both levelling valves. Press the DOWN I button to lower both platforms to the lowest position.

- e) If the platforms do not lower synchronously, open the valve that controls the slower platform and press the DOWN I button to lower it.
If the platforms no longer lower at the safety height above the floor, press the DOWN II button to lower the platforms completely. Then close the levelling valve.
- f) Close both levelling valves and press the UP button to check whether both platforms can be raised synchronously.
- g) Repeat steps 5 and 6 until synchronisation is achieved.

11) Connect the cables reserved for the limit switch and fasten the protective cover with screws.

12) Fasten base frame with expansion anchors

- a) Set the distance between the two lifting platforms and mark the points for each anchoring bolt.
- b) Drill anchor holes using an electric drill. Make sure that you drill vertically. Drill holes with a $\varnothing 16$ drill bit. Ensure that you drill vertically downwards. Hole depth: 110-120 mm.
- c) Thoroughly remove dirt and dust from the holes and check the position of the base plates again to ensure that they are correctly positioned.
- d) Use a spirit level to check the vertical alignment between the base plates. If necessary, place levelling plates under the base plates. The levelling plates must be the same length as the side of the base plate resting on them. Otherwise, the load of the base plate will not be transferred evenly to the foundation.
- e) Drive the anchoring bolt into the hole until the nut and washer touch the base.
- f) Tighten the nut to 60 Nm using a torque spanner.

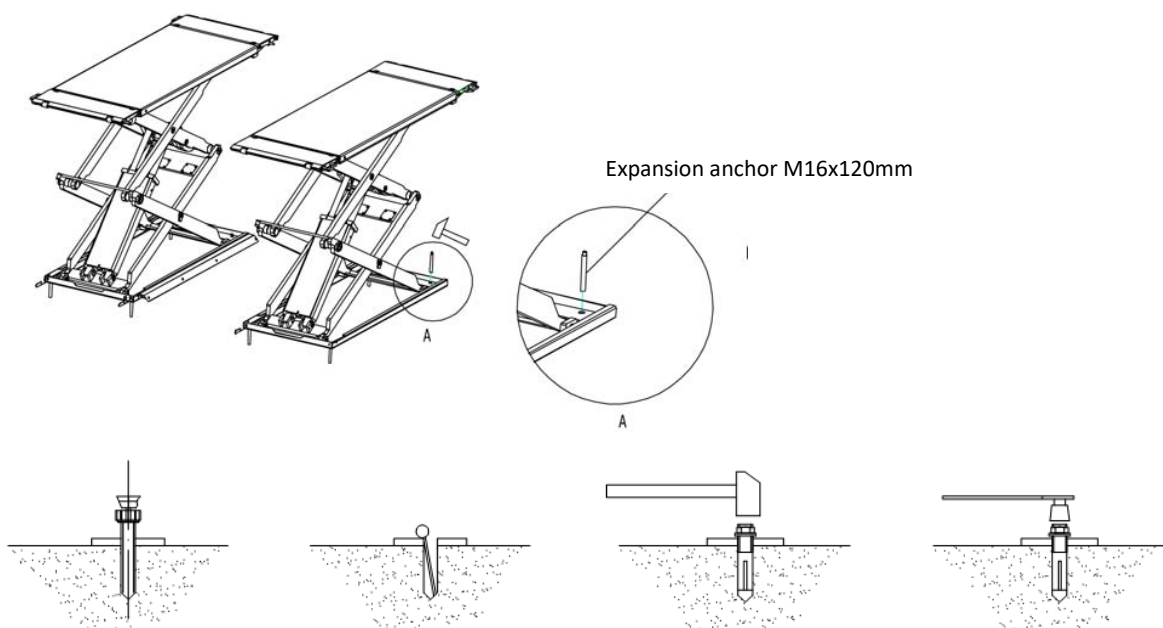

13) Fastening the oil hose protection covers

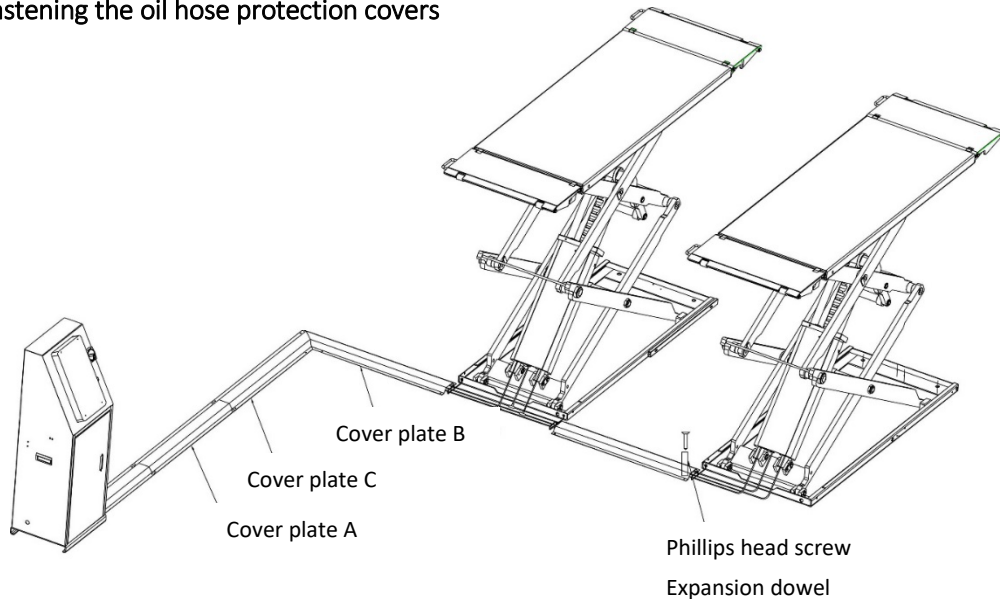

8.4 Checkpoints according to the structure

S/N	Check	YES	NO
1	Do the mechanical safety catches engage synchronously?		
2	The function switches only work when pressed and held?		
3	Is the earthing cable connected correctly?		
4	The lift raises and lowers smoothly?		
5	There are no unusual noises when operating under nominal load?		
6	There is no oil leakage under nominal load?		
7	Are the joints all screwed tight?		
8	Have all parts that need to be greased been greased?		

9. Commissioning

9.1 Safety precautions

- a) If the safety devices are defective or show abnormalities, the lift must not be put into operation under any circumstances!
- b) Check that all connections of the hydraulic lines are tight and functional. If there are no leaks, the lifting process can be started.
- c) Only the operator should be in the vicinity of the lifting platform during a lifting or lowering operation. Always ensure that there are no persons in the danger zone.
- d) Vehicles should always be aligned so that the vehicle's centre of gravity is in the middle between the lift columns. If this is not the case, the lift should not be used. Otherwise, neither we nor the dealer, if any, will accept responsibility for any problems or damage caused.
- e) When the desired lifting height is reached and the safety catches are engaged, switch off the power supply to the lift before starting work in order to avoid incidents caused by unintentional operation by other persons.
- f) Ensure that the safety catches are engaged before starting work on or under a vehicle. No persons may be in the working area of the lifting platform during the lifting and lowering process.

9.2 Description of the control unit (control box)

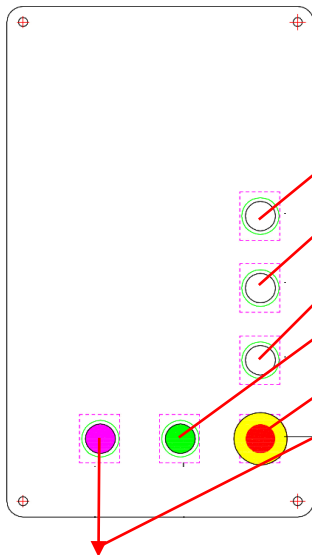

Description	Function
UP button	Raising the lifting platform
Down button 1	Lowering the lifting platform
Down button 2	Complete lowering of the lifting platform
Operating light	Indicates whether there is a power supply
Emergency stop switch	Switches the system off in an emergency
Buzzer	Flashes and beeps when draining

9.3 Lifting and lowering process flow chart

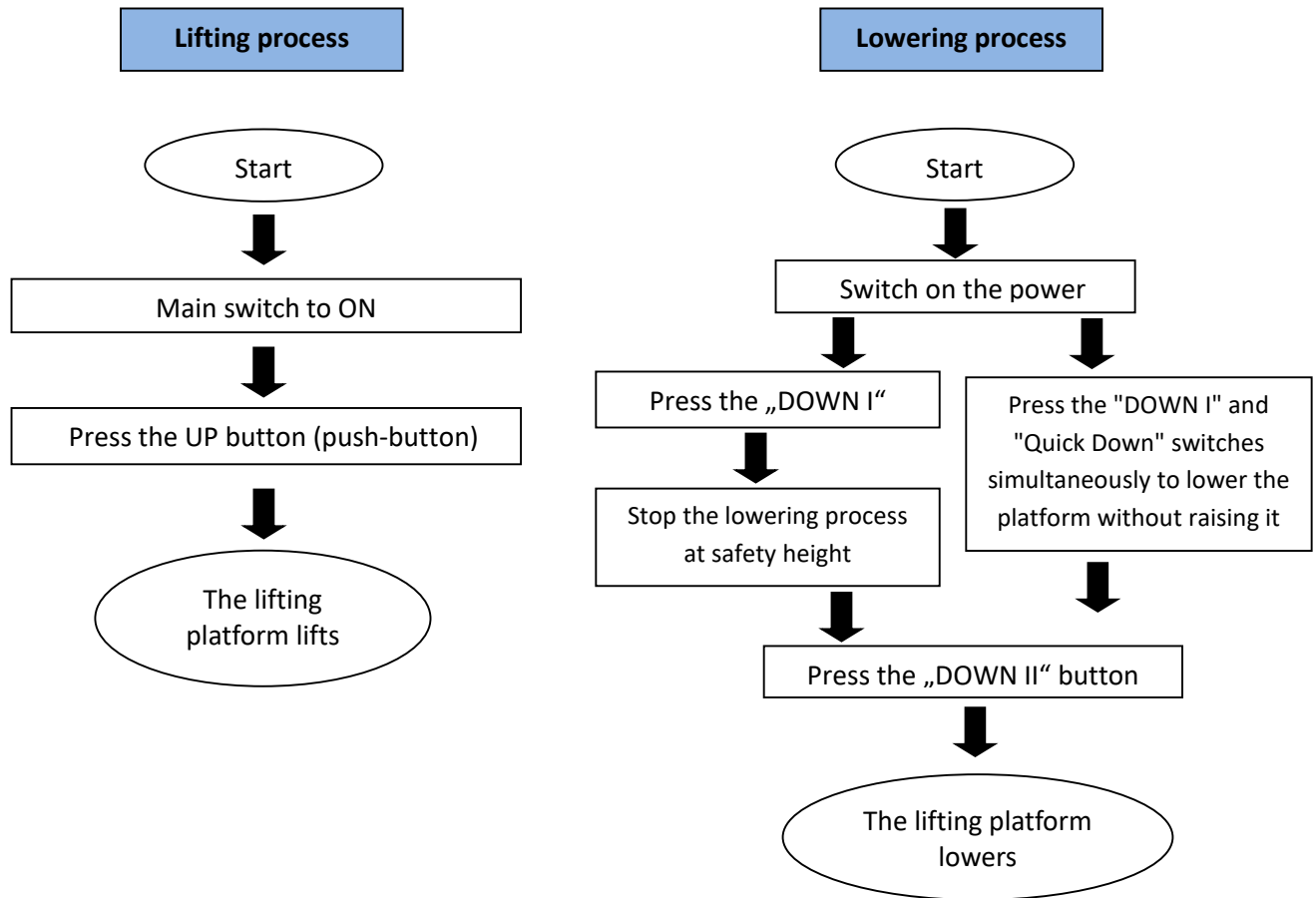

9.4 Operating instructions

9.4.1 Lifting process

1. Read and understand the operating instructions before starting work.
2. Connect the power supply and switch the main switch to ON.
3. Make sure that the vehicle is not too heavy at the front or rear and that the centre of gravity is centred between the adapters and above the lift/scissor element.
4. Carefully place the vehicle on the lift. Position the adapters/rubber blocks at the lifting points recommended by the vehicle manufacturer.
5. Press the "UP" button to raise the lift until the adapters touch the vehicle.
6. Check the adapters for correct and secure contact with the vehicle. Raise the lift to the desired working height.

9.4.2 Lowering process

1. Connect the power supply and switch the main switch to ON.
2. Press the "DOWN I" button to lower the lift. The lift is stopped in the safety stop at approx. 500 mm above the ground.
3. Press the "DOWN II" button to lower the lift completely. An audible alarm signals that you should pay particular attention when lowering the lift.

4. After lowering the lift completely, remove the rubber pads and other tools to ensure an unobstructed exit from the lifting area for the vehicle to be moved.
5. Drive the vehicle off the lift.

9.5 Emergency drain

An emergency situation arises, for example, due to a power failure. If the mechanical safety catches are not engaged, follow the steps below for emergency lowering.

Caution: Be very careful and vigilant, as this may entail potential safety risks.

1. Pull the safety catch out of the gear rack and secure it with a suitable tool.
2. Remove the protective cap and then the electric solenoid valve.

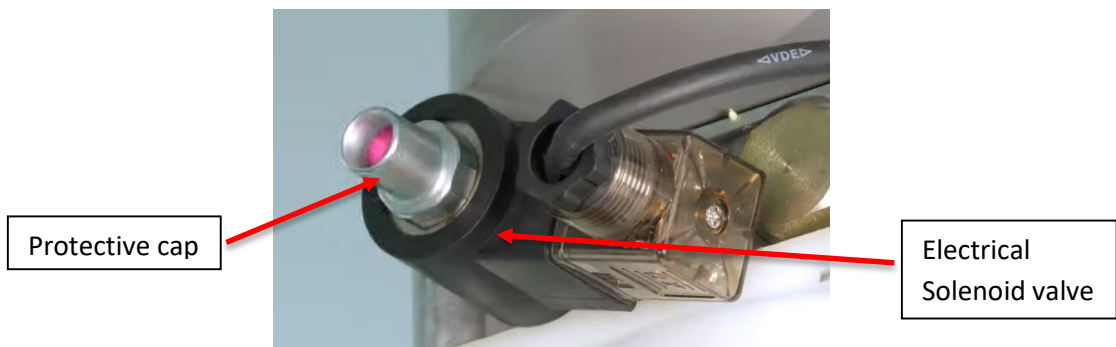

3. Slowly turn the valve insert anti-clockwise to open the valve. At this point, the lifting platform lowers.

Caution: When carrying out the above procedure, the operators must concentrate on the platforms of the lifting platform.

If an anomaly occurs, turn the valve insert clockwise until the valve is closed again and the lowering movement is stopped.

4. Secure the solenoid valve by turning the insert clockwise to the end point. Replace the solenoid valve and the protective cap.

NOTE: For different models, the images shown above may differ from the lift models, but the emergency lowering methods are the same.

10. Troubleshooting

Attention: Do not hesitate to contact the expert staff at Twin Busch GmbH if you are unable to rectify a fault yourself. We will be happy to help you solve the problem. In this case, please document the fault and send us pictures and a precise description of the fault so that we can identify and rectify the cause as quickly as possible.

The following table lists possible errors, their cause and the associated troubleshooting for quicker identification and self-remedy.

PROBLEMS	CAUSE	SOLUTION	
Unusual noise.	Wear on the inside of the pillars.	Grease the inside of the pillars.	
	Contamination in the columns.	Remove the dirt.	
The motor cannot be started, nor does the lift move up.	The cable connections are loose.	Check the cables and reconnect them.	
	The motor is defective.	Replace it.	
	The limit switch is defective/damaged or the cable connection is loose.	Reconnect the cables or replace the limit switch.	
Motor runs, but does not raise the lift.	The motor is running backwards/in the wrong direction of rotation.	Swap two of the phases to reverse the direction.	
	The pressure relief valve is loose or dirty.	Clean or screw it tight.	
	The gear pump is defective.	Replace them.	
	The oil level is too low.	Top up with oil.	
	The oil hose has come loose or is torn off.	Fasten or replace it.	
The beams lower slowly after they have been raised.	The damping valve is loose or jammed/blocked.	Clean or fasten it.	
	The oil hose is leaking.	Check or replace it.	
	The oil cylinder/piston is leaking.	Replace the seal.	
	The directional valve is leaking.	Clean or replace it.	
	The pressure relief valve is leaking.	Clean or replace it.	
Manual or electric drain valve is leaking/dirty.	Clean or replace it.		
	Lifting too slowly.	The oil filter is dirty or jammed.	Clean or replace it.
		Oil level is too low.	Top up with oil.
		The pressure relief valve is installed incorrectly.	Mount it correctly.
		The hydraulic oil is too hot. (over 45°C)	Change the oil.
The cylinder seal is worn.		Replace the seal.	
Lowering too slowly.	The throttle valve is jammed/dirty.	Clean or replace it.	
	The hydraulic oil is contaminated.	Change the oil.	
	The drain valve is blocked.	Clean it.	
	The oil hose is damaged/kinked.	Replace it.	
The steel cable is worn.	Not greased during installation or it is worn.	Replace it.	

11. Maintenance

Regular maintenance of your lift will ensure a long and safe service life. Suggestions for maintenance intervals and the activities to be carried out are listed below. How often you service your lift depends on the ambient conditions, the degree of soiling and, of course, the stress and load on the lift.

The following points must be lubricated:

S/N	Description
1	Platform Plastic glides
2	Hinge pin C
3	Hinge pin B
4	Rocker arm bolt
5	Base plate bolts
6	Hinge pin D
7	Base plates Plastic glides
8	Tilting hinge pin

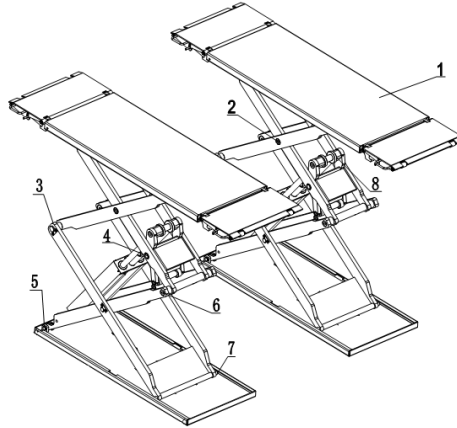

11.1 Daily inspection and maintenance of the lifting platform elements before use

A daily check of the safety-relevant components must be carried out before each start-up! This can save you a lot of time due to failure, major damage or even injury.

- Check that all connections and screw connections are tight.
- Check the electrical connections.
- Check that the oil hoses are connected correctly and that there are no leaks.
- Check that the expansion plugs are well anchored.
- Check that the safety teeth and safety block fit together properly and are not damaged.
- Clean heavily soiled lifting platform elements.
- Lubricate all lifting platform elements that are not well lubricated.

11.2 Weekly inspection and maintenance of the lifting platform elements

- Check the mobility of all moving parts and glides.
- Check the condition and correct functioning of all safety elements.
- Check the fill level of the hydraulic oil.
- Check that the expansion plugs are well anchored.

11.3 Monthly inspection and maintenance of the lifting platform

- Check that all screw connections and joints are tight.
- Check the hydraulic system for leaks and tighten the connections if they are leaking.
- Check the lubrication and abrasion conditions of the moving parts.

11.4 Annual inspection and maintenance of the lifting platform elements

- Empty and clean the hydraulic oil tank and replace the hydraulic oil.
- Replace the oil filter.

If you follow the above maintenance intervals and maintenance activities, your lift will remain in good condition and damage and accidents will continue to be avoided.

12. Behavior in the event of an incident

If the lift malfunctions, simple faults may be the cause. Use the following list for troubleshooting *).

If the cause of the error is not listed or cannot be found, please contact the expert Twin Busch GmbH team.

Never attempt to carry out repairs yourself, especially on safety devices or electrical system parts.

*) Points depending on the design and type of the lifting platform



Work on electrical systems only by qualified electricians!

Problem: Lifting platform can neither be raised nor lowered.

Possible causes

No power supply available.

Power supply interrupted.

Main switch not switched on or defective.

Emergency stop pressed or defective.

Fuse in power connection has blown or is defective.

Fuse in the switch box has blown or is defective.

Remedy

Check power supply.

Check power supply line.

Check main switch. 

Unlock emergency stop, check. 

Check fuse.

Check fuse.

Problem: Lifting platform cannot be raised.

Possible causes

With three-phase current: one phase is missing.

With three-phase current: Direction of rotation of motor reversed.

Oil pump defective.

Emergency drain open.

Motor is defective.

Overload.

Remedy

Check power supply. 

Check direction of rotation, change phase if necessary. 

Notify Twin Busch Service.

Close emergency release valve.

Notify Twin Busch Service.

Overload valve has opened, reduce load.

Problem: Lift cannot be lowered.

Possible causes

Lifting platform sits in safety catches.

Lifting platform has moved into limit switch.

Motor is defective.

Lifting platform has been blocked during lowering.

Remedy

Raise platform a little, pull detents, lower.

If necessary, loosen limit switch, raise 1 cm and lower.

Open safety latch and lift over.

Lower emergency drain.

Raise the lifting platform slightly again and remove the obstacle.

13. Appendix

13.1 Packing list for the lift

S/N	Name	Drawing/Size	Material	Description	Qty	Grade
1	Low-profile scissor lift	FL-8801		Assembly	1	A pack
2	Proection cover A	FL-8801-A9		Q235A	3	
3	Proection cover B	FL-8801-A10		Q235A	1	
4	Proection cover C	FL-8801-A11		Q235A	1	
5	Oil hose fixer	FL-8801-A1-B7		Zinc plating	3	
6	Expansion bolt	M16*160		Standard	8	
7	Cross socket cap head tapping screw	ST4.8*34		Standard	20	A pack
8	Control cabinet	FL-8802-A10		Assembly	1	
9	Plastic expansion tube	M10*40		Standard	20	
10	Rubber pad	FL-8801-A14		Rubber	4	

13.2 Dimensions of the lift

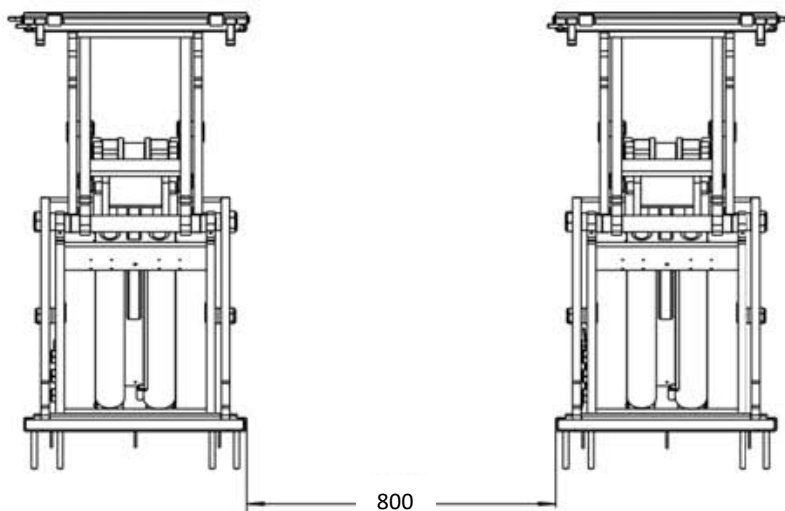

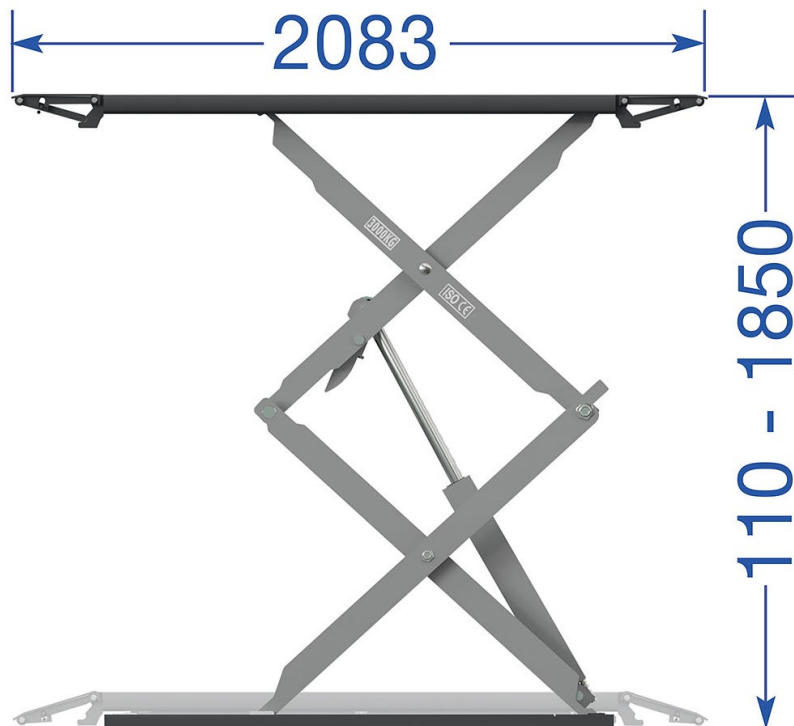
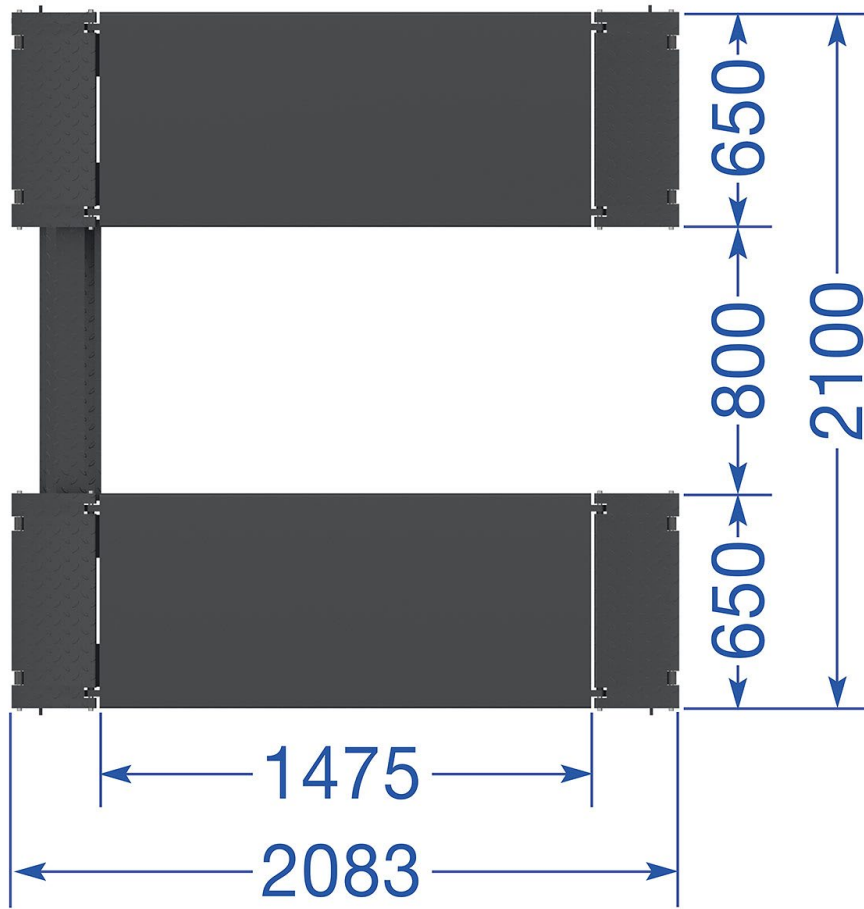

13.3 Foundation requirements and working area

Requirements for the concrete:

- Concrete C20/25 according to DIN 1045-2 (previous designation: DIN 1045 concrete B25).
- The floor must be level and have a flatness of less than 5 mm/m.
- Newly poured concrete must cure for at least 28 days.

Foundation dimensions:

- Ideally, the entire hall floor should be made of C20/25 concrete with a thickness of at least 150 mm.
- In all lifting positions, there must be a distance of at least 0.8 metres between the lifting platform and the fixed elements (e.g. the wall).

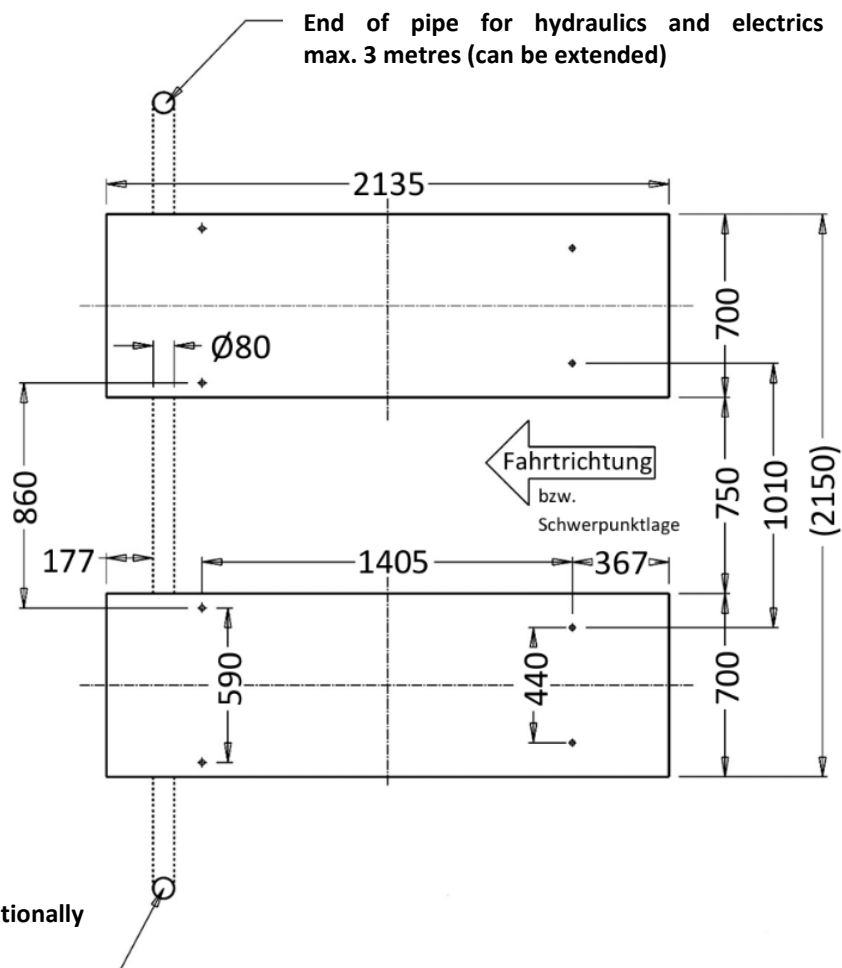
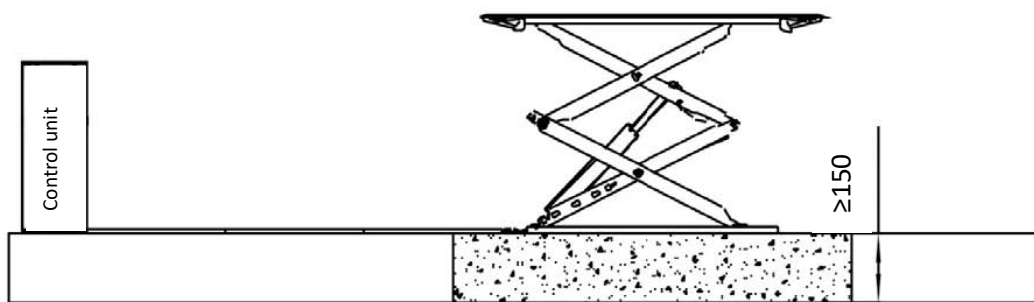

Note: For these dimensions, the handles and pins of the latches must be cut off or shortened.

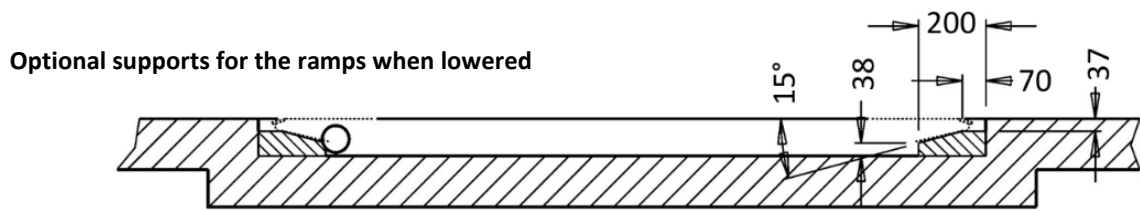

Other requirements:

- The surrounding soil must be suitable for the load, e.g. no sandy soils, etc.
- Reinforcements in the concrete are not mandatory for proper use of the lift, but are recommended.
- If in doubt, the foundation should be determined and checked by a structural engineer.

The following must be observed for soil exposed to frost:

In the case of frost exposure, the concrete must correspond to exposure class XF4, as dripping de-icing agent cannot be ruled out.

This results in the following minimum requirements for concrete under frost stress:

Exposure class:	XF4
Maximum w/c:	0,45
Minimum compressive strength:	C30/37 (instead of C20/25)
Minimum cement content:	340 kg/m ³
Minimum air void content:	4.0 %

However, it must be noted that the lifts are not designed for outdoor use. Although the control box complies with IP54, the rest of the electrics, motors and limit switches have a maximum IP44 rating.

13.4 Hydraulic system

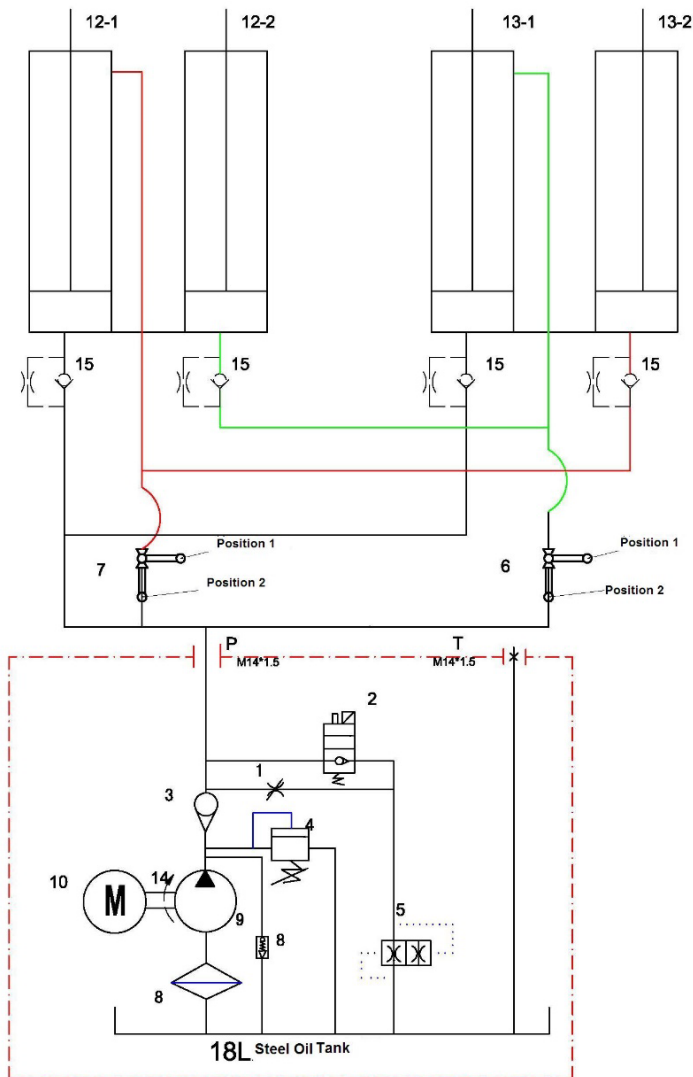

1. Emergency release valve
2. Electromagnetic drain valve
3. Overflow valve
4. Lower throttle valve
5. Ball valve for oil replenishment
6. Ball valve for oil replenishment
7. Damping valve
8. Gear pump
9. Oil pump motor
10. Oil filter

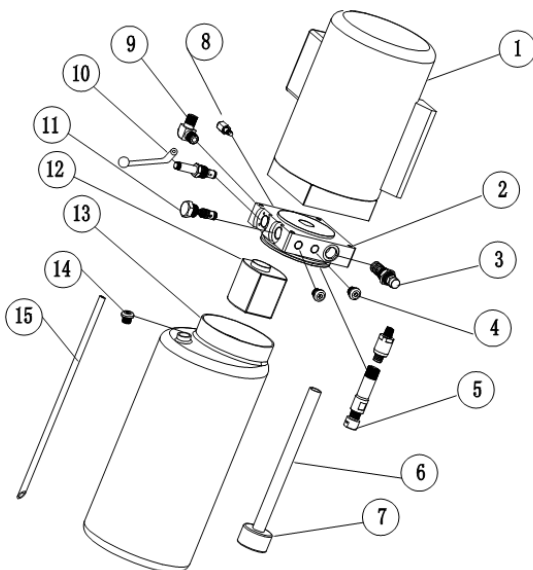

S/N	Name	Quantity
1	Motor	1
2	Hydraulic block	1
3	Pressure relief valve	1
4	Screw plug	2
5	Pressure control valve	1
6	Oil intake pipe	1
7	Oil filter	1
8	Throttle valve	1
9	Connection link	1
10	Electromagnetic drain	1
11	One-way valve	1
12	Gear pump	1
13	Plastic oil tank	1
14	Oil tank plug	1
15	Oil return line	1

13.5 Circuit diagrams

1-phase

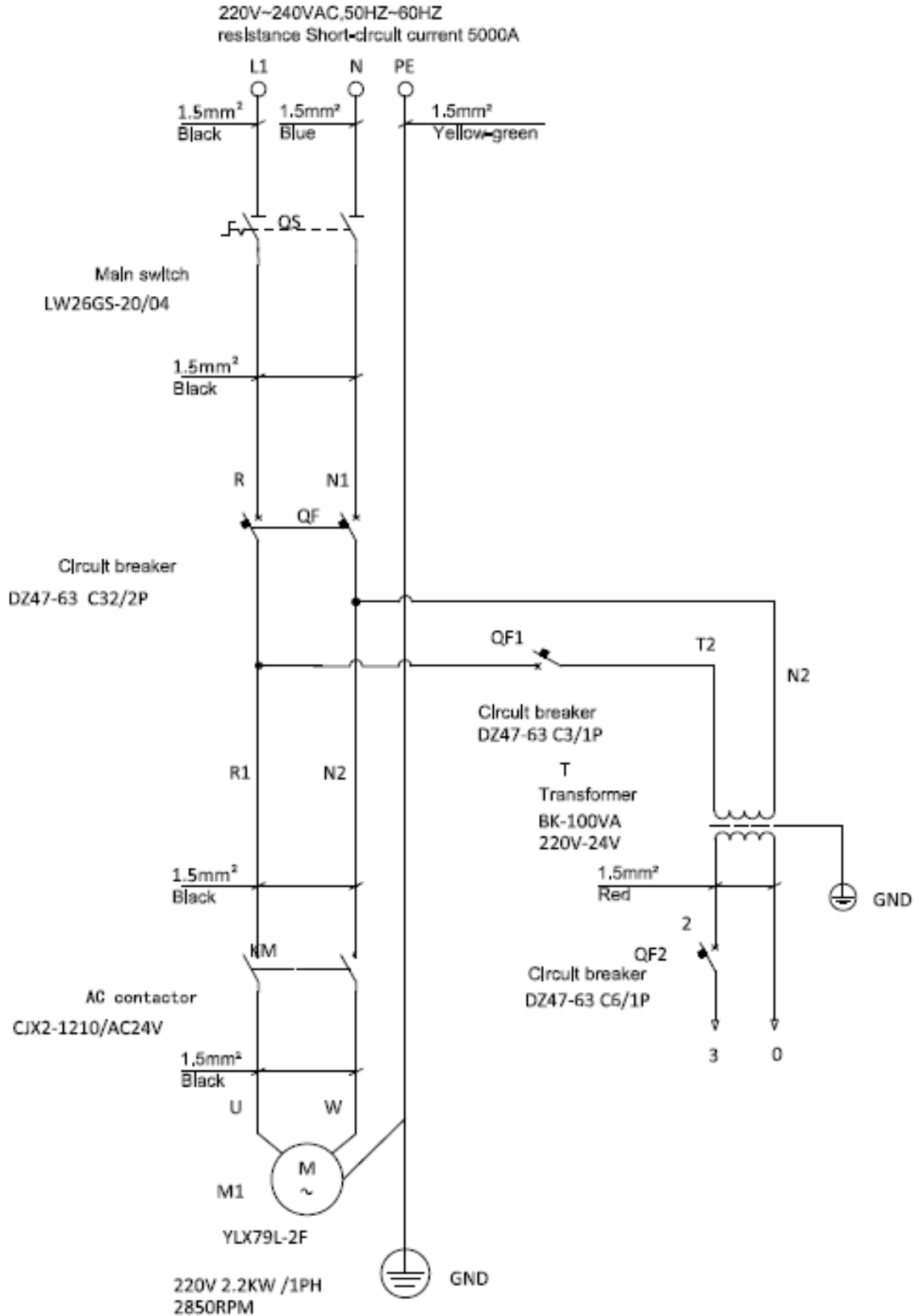

3-phase

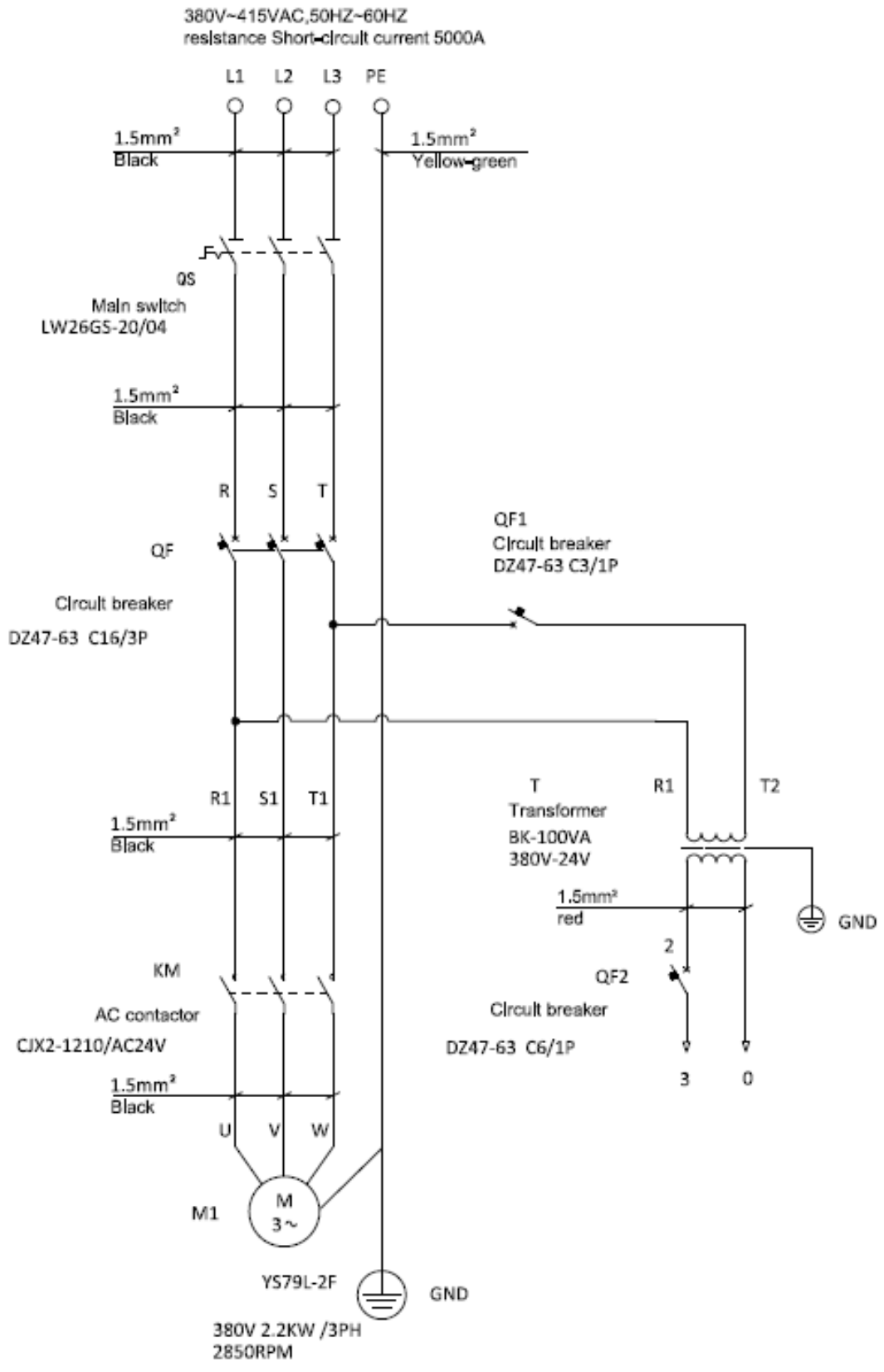

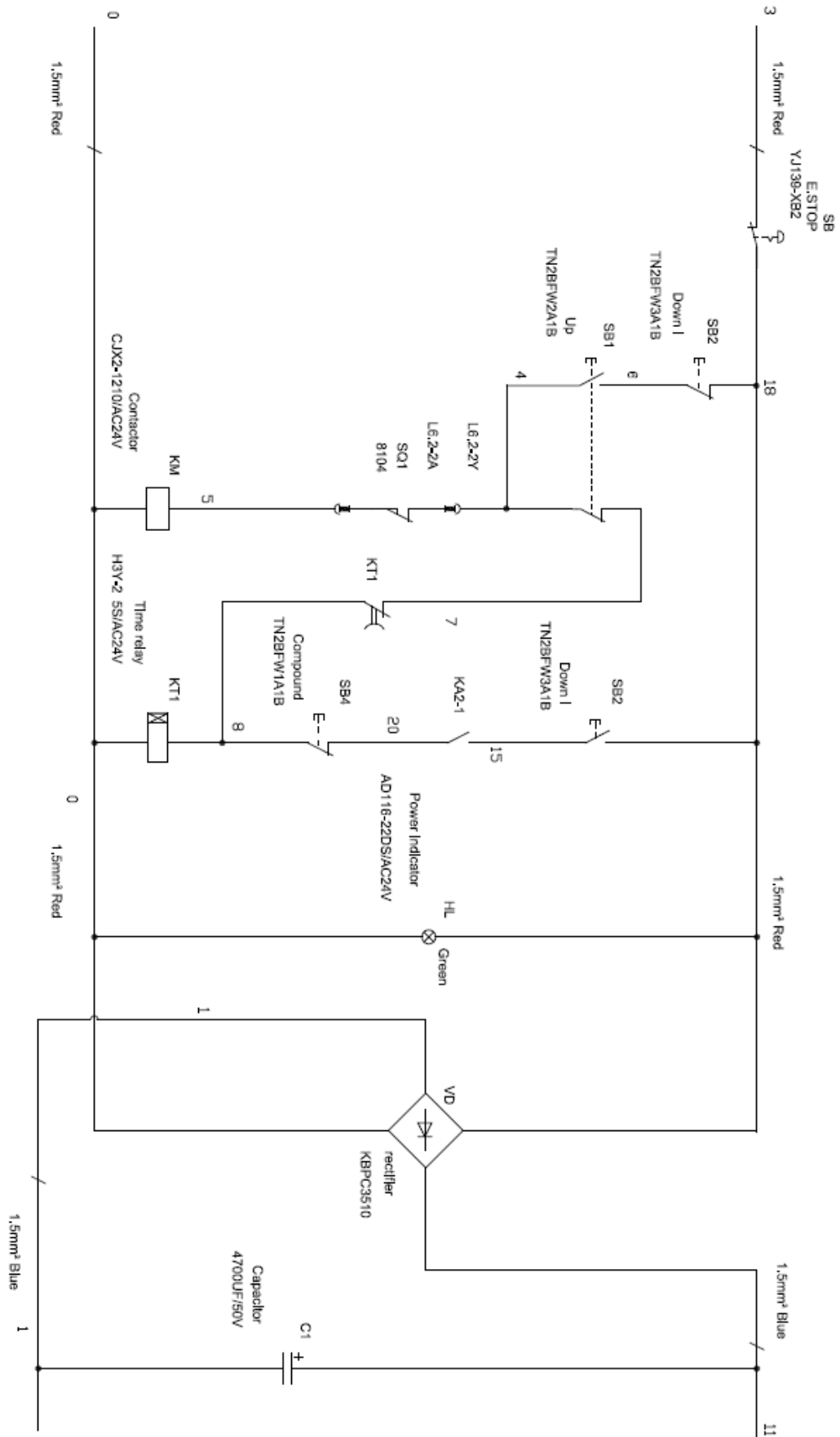

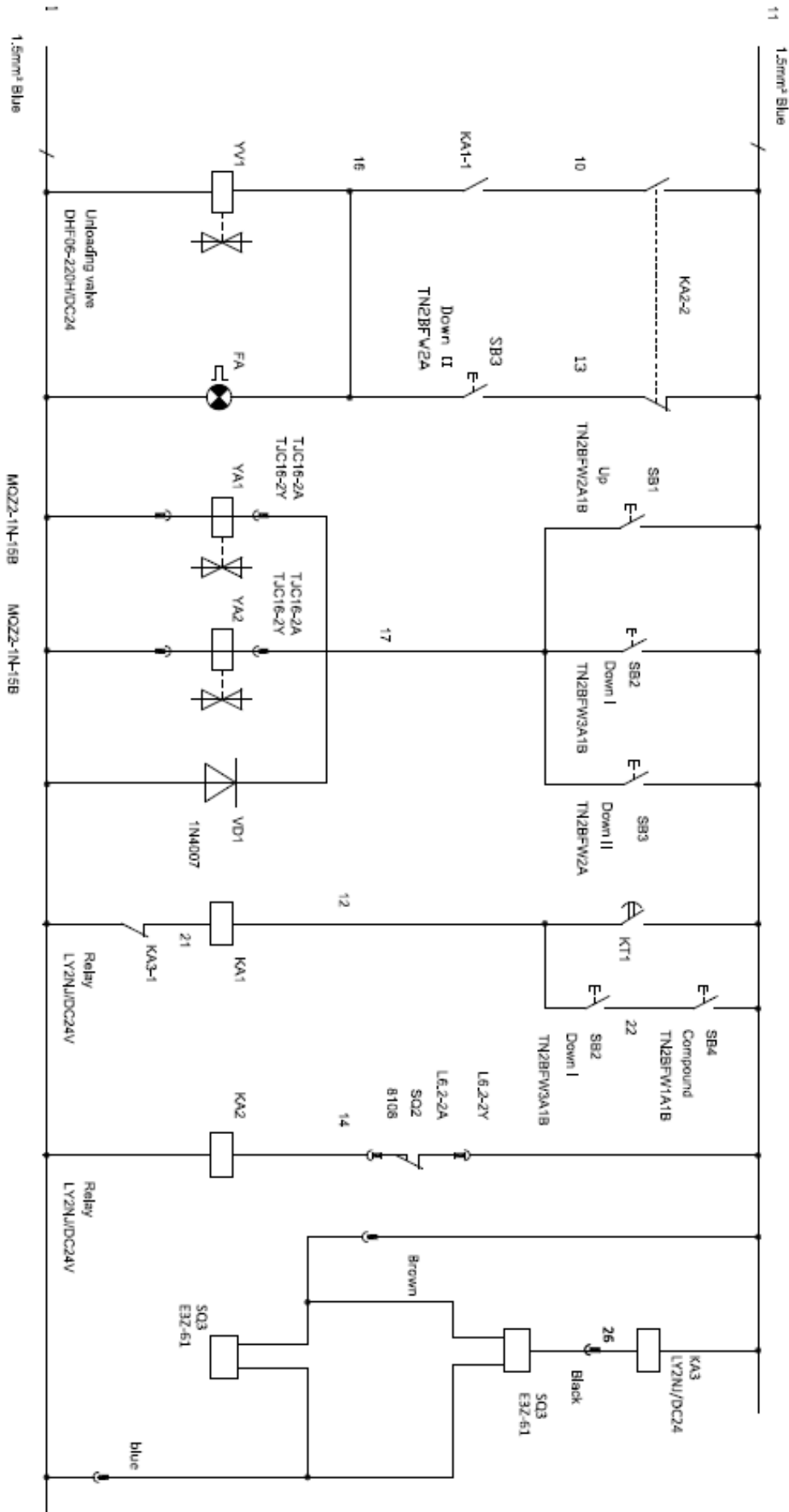

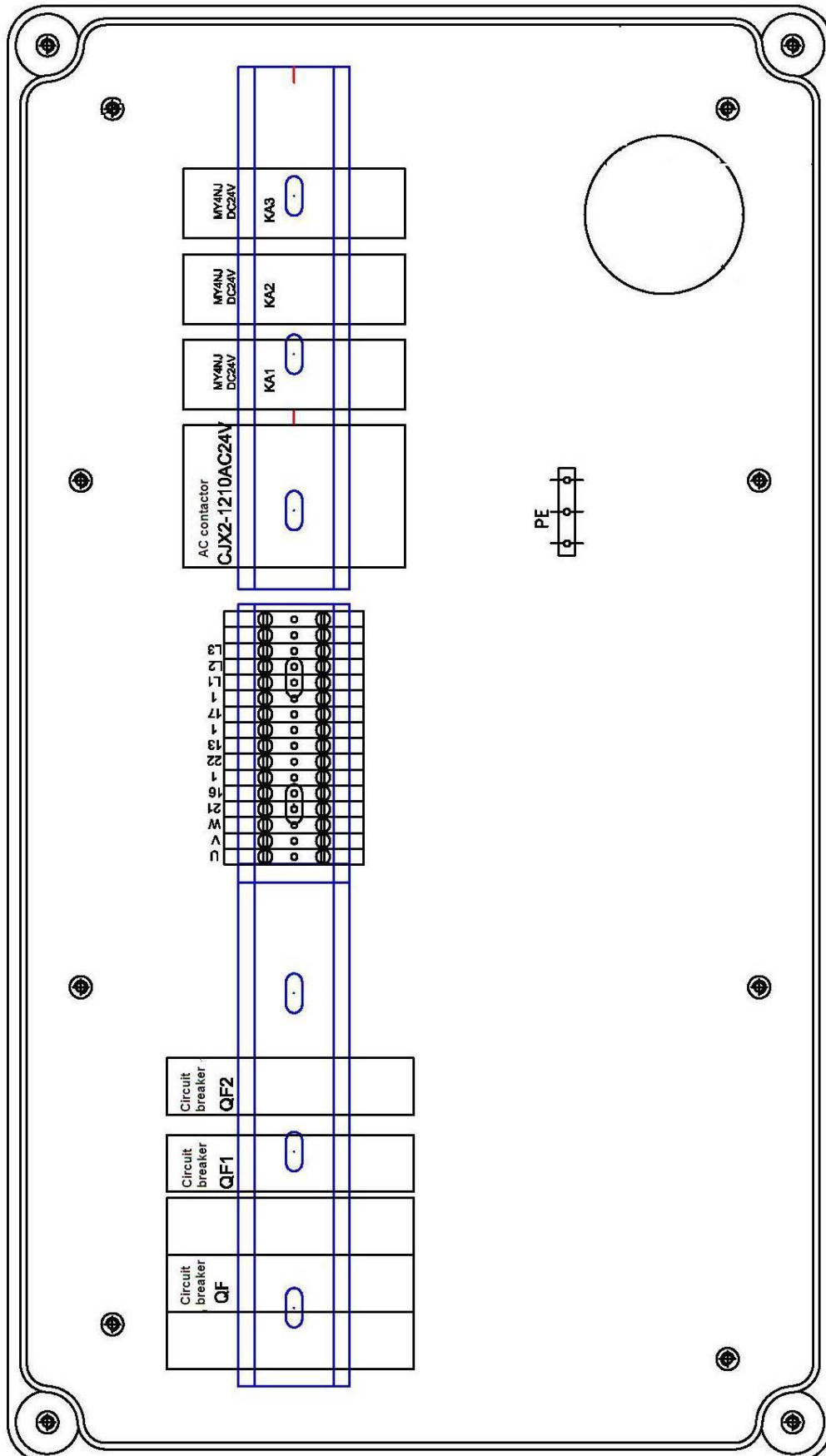

13.6 Detailed drawing and parts description of the lift

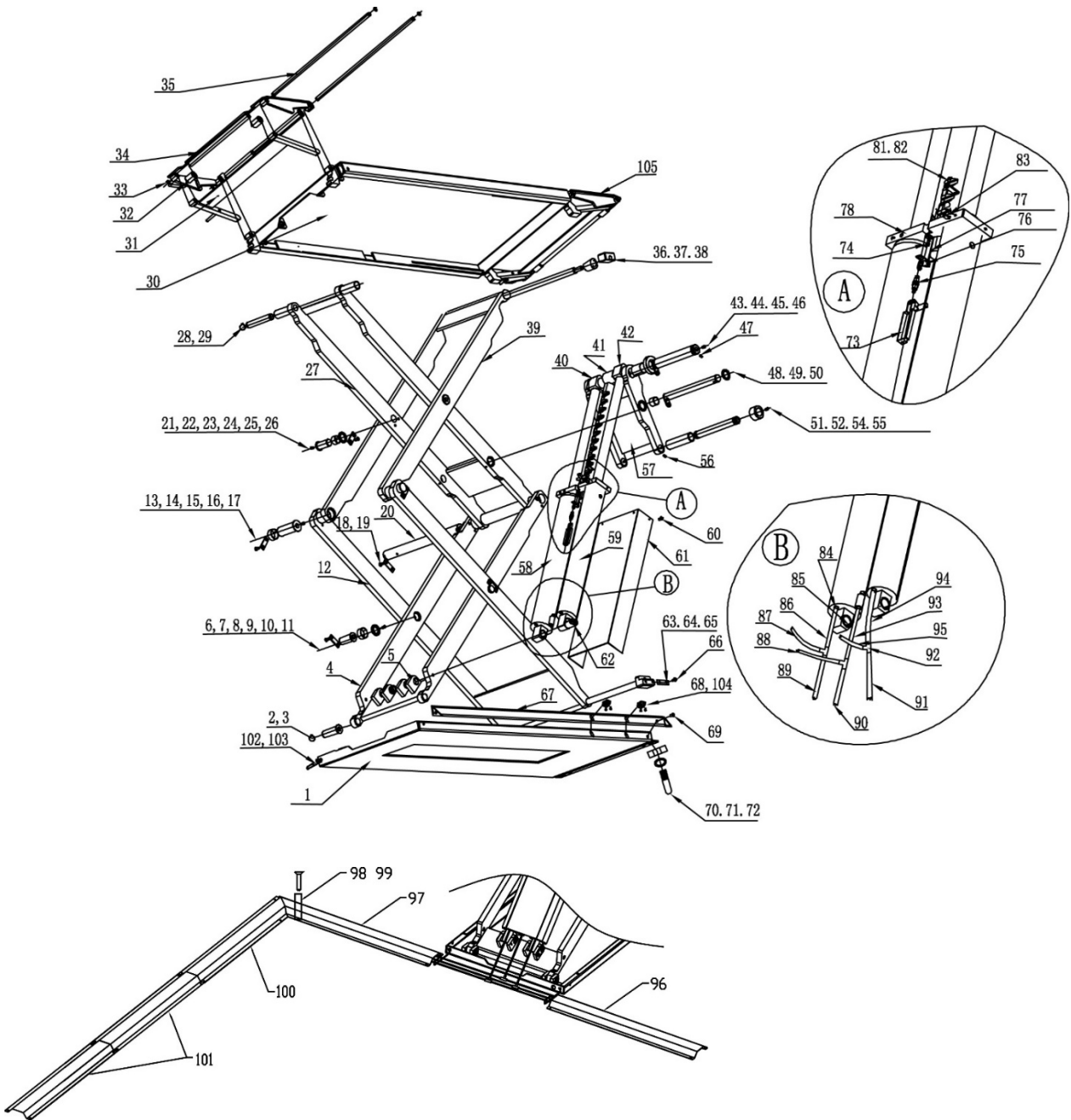

S/N	Material	Name	Drawing	Qty	Property	Grade
1		Base plate A	FL-8801-A1-B1	1	Welded	
3		Rotor shaft	FL-8801-A1-B5	4	45#	
4		Movable arm C	FL-8801-A2-B3	2	Welded	
5		Hex head cone screw M6*10	GB/T78-2000	16	Standard	Total qty
6		Self-lock screw	M27*3	4	Standard	
8		Joint shaft C	FL-8801-A2-B6	4	45#	
9		Bearing 3025	SF-1	8	Standard	Total qty

S/N	Material	Name	Drawing	Qty	Property	Grade
10		Thick spacer	FL-8801-A2-B7	8	Q235A	
11		Oil nozzle M8*1	JB/T7940.1-1985	32	Standard	Total qty
12		Movable arm B	FL-8801-A2-B1	2	Welded	
13						
14		Self-lock screw	M36*3	4	Standard	
15		Bearing 4050	SF-1	4	Standard	
16		Joint shaft BB	FL-8801-A2-B9	4	45#	
17		Oil nozzle M8*1	JB/T7940.1-1985		Standard	Same as item 11
18		Oil nozzle M8*1	JB/T7940.1-1985		Standard	Same as item 11
19						
20		Joint shaft D	FL-8801-A2-B12	2	45#	
21		Oil nozzle M8*1	JB/T7940.1-1985		Standard	Same as item 11
22		Joint shaft C	FL-8801-A2-B6	4	45#	
23		Bearing 3025	SF-1		Standard	Same as item 9
24		Thin spacer	FL-8801-A2-B8	4	Q235A	
25						
26		Self-lock screw	M27*3	4	Standard	
27		Movable arm A	FL-8801-A2-B2	2	Welded	
28		Circlip 25	GB/T894.1-2000	8	Standard	
29		Rotor shaft	FL-8801-A5-B2	4	45#	
30		Platform	FL-8801-A5-B3	2	Welded	
31		Supporting rod	FL-8801-A5-B1-C6	1	Welded	
32		Small wheel	MR30-A22-B5	4	Nylon1010	
33		Circlip 25		8	Standard	
34		Ramp A	FL-8801-A5-B1	2	Welded	
35		Ramp shaft	FL-8801-A5-B1-C4	4	45#	
36		Rotor shaft	FL-8801-A2-B15	2	45#	
37		Wheel	FL-8801-A2-B16	4	Q235A	
38		Pad	FL-8801-A2-B17	4	Nylon1010	
39		Movable arm B	FL-8801-A2-B1	2	Welded	
40		Cylinder connector A	FL-8801-A4-B11	2		
41		Safety teeth	FL-8801-A4-B2	2	Welded	
42		Oil connector B	FL-8801-A4-B1	2		
43		Oil nozzle M8*1	JB/T7940.1-1985		Standard	Same as item 11
44		Cylinder shaft	FL-8801-A3-B1	2	Welded	
45		Cylinder wheel	FL-8801-A4-B12	4	45#	
46		Bearing 4040	SF-1	4	Standard	
47		Inside hex cap screw M8*12	GB/T78-2000	16	Standard	Same as item 5
48		Thin spacer	FL-8801-A2-B8	4	Q235A	
49		Rotor shaft	FL-8801-A3-B6	2	Welded	
50		Bearing 3025	SF-1	4	Standard	
51		Oil nozzle M8*1	JB/T7940.1-1985		Standard	Same as item 11
52		Start wheel	FL-8801-A3-B4	4	Q235A	
54		Start rotor shaft	FL-8801-A3-B3	2	45#	
55		Wheel retaining ring	FL-8801-A3-B5	2	Q235A	
56		Inside hex cone screw M6*10	GB/T78-2000	16	Standard	Same as item 5
57		Start plate	FL-8801-A3-B2	2	Welded	
58		Drive oil cylinder	FL-8801-A4-B8	2	Assembly	

S/N	Material	Name	Drawing	Qty	Property	Grade
59		Oil cylinder	FL-8801-A4-B7	2	Assembly	
60		Cross cap screw M5*10	GB/T78-2000	4	Standard	
61		Oil cylinder sheath	FL-8801-A4-B14	2	Q235A	
62		Cylinder shaft	FL-8801-A4-B9	4	Welded	
63		Position limit plate	FL-8801-A2-B19	1	Q235A	
64		Position limit slider	FL-8801-A2-B18	1	Nylon1010	
65		Down shaft	FL-8801-A2-B11	2	45#	
66		Cross flat head screw M8*16	GB/T78-2000	2	Standard	
67						
68		Proximity switch		2	Assembly	Optical limit switch
69		Cross cap screw M6*10	GB/T818-2000	4	Standard	
70		Hex nut M16	GB/T41-2000	8	Standard	With expansion bolt
71		Washer 16		8	Standard	With expansion bolt
72		Expansion bolt M16*160		8	Standard	
73		Safety block	FL-8801E-A4-B5	2	Welded	
74		Cross cap screw M5*10	GB/T78-2000	2	Standard	
75				2	Assembly	
76		electromagnet	MQZ2-10N-A5B	2	Assembly	
77				2	Welded	
78		Oil cylinder flange	FL-8801E-A4-B3	2	45#	
79		Cylinder pin $\Phi 4 \times 14$	GB/T119.1-2000	2	Standard	
80		Safety block	FL-8801-A4-B4	2	45#	
81				14	Standard	
82		Safety block pressure plate	FL-8801E-A4-B4	4	Q235A	
83		Inside hex cone screw M8*20	GB/T78-2000	4	Standard	
84		Connector B		4	45#	
85		Bearing 2840	SF-1	4	Standard	
86		Oil hose	FL-8801-A8	1	Assembly	0.27m
87		Oil hose	FL-8801-A8	1	Assembly	1.65m
88		Oil hose	FL-8801-A8	2	Assembly	1.65m
89		Oil hose	FL-8801-A8	1	Assembly	4.2m
90		Oil hose	FL-8801-A8	1	Assembly	4.2m
91		Oil hose	FL-8801-A8	1	Assembly	4.2m
92		Three-way connector G1/4	FL-8801-A4-B7	3	45#	
93		Oil hose	FL-8801-A8	1	Assembly	0.25m
94		Oil hose		1	Assembly	0.23m
95		Oil hose	FL-8801-A8	1	Assembly	1.65m
96		Protection cover plate A	FL-8801-A9	3	Q235A	
97		Protection cover plate B	FL-8801-A10	1	Q235A	
98	94010100727	Cross cap screw ST4.8*34	ST4.8*34	20	Standard	
99	94010100285	Plastic expansion pipe	M10*40	20	Standard	
100	95200103051	Protection cover plate C	FL-8801-A11	1	Q235A	
101	95200103049	Protection cover plate A	FL-8801-A9	2	Q235A	
102		Oil hose fixer	FL-8801-A1-B7	3	65Mn	
103		Hex head full swivel bolt M8*15	GB/T5781-2000	1	Standard	
105		Guiding plate B	FL-8801-A5-B4	2	Welded	

13.7 Spare parts list

S/N	Material	Name	Spec.	Unit	Qty/set	Pictures
1		Power switch	LW26GS-20/04	Pcs	1	
2		Button	Y090	Pcs	3	
3		Power indicator	AD17-22G-AC24	Pcs	1	
4		Transformer	JBK-63VA220V-24V	Pcs	1	Same outlook as item7
5		Transformer	JBK-63VA230V-24V	Pcs	1	Same outlook as item7
6		Transformer	JBK-63VA240V-24V	Pcs	1	Same outlook as item7
7		Transformer	JBK-63VA380V-24V	Pcs	1	
8		Transformer	JBK-63VA400V-24V	Pcs	1	Same outlook as item7
9		Transformer	JBK-63VA415V-24V	Pcs	1	Same outlook as item7
10		AC contactor	CJX2-1210/AC24	Pcs	1	
11		Circuit breaker	DZ47-63 C16 /3P	Pcs	1	
12		Circuit breaker	DZ47-63 C32 /2P	Pcs	1	
13		Circuit breaker	DZ47-63 C3 /1P	Pcs	1	
14		Pneumatic valve	3V210-08/DC24	Pcs	1	
15		Limit switch	ME8104	Pcs	1	

S/N	Material	Name	Spec.	Unit	Qty/set	Pictures
16		Bridge rectifier	KBPC5A-35A	Pcs	1	
17		Capacitor	4700UF/50V	Pcs	1	
18		Control box	Bigger	Pcs	1	
19		Relay	MY4NJ/DC24	Pcs	3	
20		Relay holder	PYF14AE	Pcs	1	
21		Limits switch	8108 (TZ8108)	Pcs	1	
22		Photoelectric Sensor	E3Z-61	PCS	2	

Mechanical spare parts

S/N	Material	Name	Drawing	Qty/set	Description	Grade
1		Straight oil cup M8*1	JB/T7940.1-1985	32	Standard	
2		Pad block	FL-8801-A2-B17	4	Nylon	
3		Positioning slider	FL-8801-A2-B13	4	Nylon 1010	
4		Safety block connection	FL-8801-A4-B5	2	Q235A	
5		Air cylinder	CDJ2B10-30-S	2	Assembly	
6		Fixing plate for air cylinder	FL-8801-A4-B15	2	Q235A	
7		Coverage plate for safety block	FL-8801-A4-B4	4	Q235A	
8		Cover A	FL-8801-A9	3	Q235A	
9		Cover B	FL-8801-A10	1	Q235A	
10		Cover C	FL-8801-A11	1	Q235A	
11		Y- seal ring	B7-80*65*9	1		
12		Y-seal ring	SD38*48*6	1		
13		Anti-dust ring	BHS38*46*6	2		
14		Y-seal ring	B7-70*55*9	1		



The company

Twin Busch GmbH | Amperestr. 1 | D-64625 Bensheim

hereby declares that the **scissor vehicle lift**

TWS3-19E | 3000 kg

Serial number:

in these configurations we have placed on the marked complies with the relevant essential health and safety requirements of the following EC-directive(s) in its/their current version(s).

EC-directive(s)

2006/42/EC

machinery

2014/35/EU

low voltage

Applied harmonized standards and regulations

EN 1493:2022

Vehicle Lifts

EN 60204-1:2008

Safety of machinery

CE Certificate

N8MA 087411 0050 Rev.01

date of issue: 25.03.2022

M6A 087411 0049 Rev.01

place of issue: München

technical file no.: 646642303501

Certification body

TÜV SÜD Product Service GmbH,

Ridlerstraße 65,

80339 München

Notified Body Appointment No.: 0123

In the case of improper use, as well as in the case of assembling, modification or changes which are not agreed with us, this declaration will lose its validity.

Authorized person to compile technical documentation is: Michael Glade (adress as below)



TWIN BUSCH GmbH

Amperestr. 1 · 64625 Bensheim

Tel. 06251 / 70585-0 · Fax: 70585-29

Authorized signatory: Michael Glade
Bensheim, 25.10.2023 Qualitätsmanagement

Twin Busch GmbH | Amperestr. 1 | D-64625 Bensheim

twinbusch.de | E-Mail: info@twinbusch.de | Tel.: +49 (0)6251-70585-0



You can find more products at:

twinbusch.co.uk

Twin Busch UK LTD
Kettering
Northants NN16 8PS

Tel.: +44 (0) 1536 522 960
E-Mail: info@twinbusch.co.uk
Web: www.twinbusch.co.uk

The technical specifications and illustrations provided in the user manual are not binding. Our products are subject to technical changes, so the delivered condition may vary.