



**2-POST-LIFTS**  
TW 242GE BASIC-Line, Garage model  
(Lifting capacity: 4200 kg)

# **TW 242GE**

## **INSTALLATION, OPERATION AND MAINTENANCE MANUAL**



*Always read these operating instructions carefully before operating the lift. Follow the instructions carefully.*

## Table of contents

<b>1. General information .....</b>	<b>1</b>
<b>2. Identification of the instructions for use .....</b>	<b>1</b>
<b>3. Technical data.....</b>	<b>1</b>
<b>4. Modification of the product .....</b>	<b>1</b>
<b>5. Important notes / warnings.....</b>	<b>2</b>
5.1 Important note .....	2
5.2 Specialised personnel.....	2
5.3 Safety instructions .....	2
5.4 Safety devices .....	3
5.5 Monitoring and testing the safety equipment.....	3
5.6 Warnings and symbols .....	4
5.7 Load distribution.....	5
<b>6. Compliance with the product .....</b>	<b>5</b>
<b>7. Technical specification .....</b>	<b>5</b>
7.1 General technical description .....	5
7.2 Machine description .....	6
<b>8. Installation .....</b>	<b>7</b>
8.1 Before installation .....	7
8.2 Precautions before installation.....	7
8.3 Structure.....	8
8.4 Checkpoints after installation.....	16
<b>9. Operating instructions .....</b>	<b>17</b>
9.1 Safety precautions.....	17
9.2 Flow chart.....	17
9.3 Operating instructions (lifting and lowering process).....	18
9.4 Description of the switch box (control box).....	18
<b>10. Operating instructions .....</b>	<b>19</b>
<b>11. Maintenance .....</b>	<b>20</b>
11.1 Daily inspection of parts before operation.....	20
11.2 Weekly inspection of the parts .....	20
11.3 Monthly inspection of parts.....	20
11.4 Annual inspection of the parts.....	21
<b>12. Behaviour in the event of an incident .....</b>	<b>21</b>

<b>13. Appendix</b> .....	<b>22</b>
13.1 Packing list for the lift.....	22
13.2 General diagram .....	23
13.3 Diagram for floor fastening / foundation plan .....	24
13.4 Hydraulic system .....	27
13.5 Circuit diagrams .....	28
13.6 Exploded views .....	33
13.7 Spare parts list .....	39

**Further attachment:**

- **EU Declaration of Conformity**



## TIPS & TRICKS



In the "Tips & Tricks" section we show you simple solutions to work even more efficiently with your TWIN BUSCH® products.

[www.twinbusch.co.uk/2-post-lifts/BASIC-Line-Lift-4-2-t-BASIC-LINE-Garage-Model::278.html#horizontalTab4](http://www.twinbusch.co.uk/2-post-lifts/BASIC-Line-Lift-4-2-t-BASIC-LINE-Garage-Model::278.html#horizontalTab4)

## 24/7 Service Center:



Our **24/7 Self-Service Center** is a mobile website designed for self-diagnosis of issues with your Twin Busch lift. Here, we provide an extensive video collection covering a wide range of relevant topics for your Twin Busch lift, from fine-tuning and maintenance to component replacement.

With the **24/7 Self-Service Center**, you have a versatile tool at your disposal to learn how to independently maintain and repair your Twin Busch lift.

To access the site on your mobile device, please visit [twinbusch.com/qr](http://twinbusch.com/qr) or scan the QR code provided alongside.

For Twin Busch lifts shipped from mid-2020 onwards, you'll also find the QR code on a sticker attached to the control box.

## 1. General information

Garage model - Only recommended for standard garages with width restrictions and low ceiling heights! The **TW242GE** BASIC-Line lift was specially developed for limited space conditions. With an overall width of less than 3 m and a column height of just 2.32 m, it is the ideal solution for standard garages. The automatic safety locking and unlocking function not only ensures effortless operation, but also additional safety when using the lift.

## 2. Identification of the instructions for use

Operating instructions **TW 242 GE**

of the Twin Busch GmbH  
 Ampèrestraße 1  
 D-64625 Bensheim

Twin Busch UK Ltd.  
 9, Linnell Way  
 Telford Way Industrial Estate  
 NN16 8PS, Kettering (Northants)

Phone: +49 6251-70585-0  
 Telefax: +49 6251-70585-29  
 Internet: [www.twinbusch.de](http://www.twinbusch.de)  
 Email: [info@twinbusch.de](mailto:info@twinbusch.de)

Phone: +44 (0) 1536 522 960  
 Internet: [www.twinbusch.co.uk](http://www.twinbusch.co.uk)  
 Email: [info@twinbusch.co.uk](mailto:info@twinbusch.co.uk)

Status: -03, 03.06.2024

File: TW242GE\_2-post\_lift\_garage\_model\_manual\_en\_03\_20240603.pdf

## 3. Technical data

Power supply	230 V / 50 Hz
Protection	C 16A (slow)
Load capacity	4,200 kg
Degree of protection	IP 54
Lifting time	approx. 45 sec
Lowering time	approx. 30 sec
Net weight	540 kg
Noise level	< 70 db
Working environment	Working temperature: -15°C to +40°C
	rel. Humidity: 30 % to 85 %

## 4. Modification of the product

Improper use, modifications, conversions and attachments of the lift and all its components that have not been agreed with the manufacturer are not permitted. The manufacturer accepts no liability for improper installation, operation or overloading. Improper use also invalidates the CE certification and the validity of the certificate. If you require any changes, please contact your dealer or the expert staff at Twin Busch GmbH beforehand.

## 5. Important notes / warnings

### 5.1 Important note

Neither the manufacturer nor the seller will accept liability for improper installation, improper operation, overloading or unsuitable ground conditions.

This model is specially designed for lifting cars that do not exceed the maximum authorised weight. If you use the lift for other purposes, neither the manufacturer nor the seller will be liable for accidents or damage.

Pay particular attention to the maximum authorised weight. A sign with the maximum authorised weight is attached to the lift.

Never attempt to lift vehicles that exceed the authorised maximum weight with the lift.

**Read the operating instructions carefully before operating the lift to avoid personal injury.**

### 5.2 Specialised personnel

- Only trained specialist personnel may operate the lift. Read and understand the safety instructions before operating the lift.
- **Electrical connections must be made by an electrician.**
- Bystanders are not permitted in the vicinity of the lifting platform.

### 5.3 Safety instructions

- Do not install the lift on an asphalt surface.
- Read and understand the safety instructions before operating the lift.
- Do not leave the control unit under any circumstances when the lift is in motion.
- Keep hands and feet away from moving parts. When lowering, pay particular attention to your feet.
- The lifting platform may only be operated by trained personnel.
- Wear suitable clothing.
- The area around the lifting platform should always be kept free of obstructions.
- The lift is designed for lifting the entire vehicle, which does not exceed the maximum authorised weight.
- Always ensure that all safety precautions have been taken before working near or under the vehicle.  
**Never remove safety-relevant components from the lift. Do not use the lift if safety-relevant components are missing or damaged.**
- Do not under any circumstances move the vehicle or remove heavy objects from the vehicle that could cause significant weight differences while the vehicle is on the lift.
- Always check the manoeuvrability of the lift to guarantee its performance.  
Ensure regular maintenance. If an irregularity occurs, stop the work with the lift immediately and contact your dealer.
- Lower the lift completely when it is not in use. Do not forget to disconnect the power supply.
- If you do not use the lift for a longer period of time:
  - a.) Disconnect the lift from the power source.
  - b.) Empty the oil tank.
  - c.) Lubricate the moving parts with hydraulic oil.

**Caution: To protect the environment, dispose of the unused oil in an appropriate manner.**

## 5.4 Safety equipment

The lift is equipped with the following safety devices to ensure safe operation \*):

- Safety catches
- Throttle valve in hydraulic line
- Limit switch
- Support arm lock
- Devices to prevent jamming and crushing (shaft protection, foot deflector)
- Synchronisation cables

\*) depending on the design and type of lift

## 5.5 Monitoring and testing the safety equipment

- |                          |  |
|--------------------------|--|
| · Safety catches         | Function test, when lowering the lift, safety catches must engage and stop the downward movement.                          |
| · Throttle valve         | Fixed throttle, cannot be checked by the user.   |
| · Limit switch           | If the limit switch is pressed, the motor stops or cannot start.   |
| · Support arm lock       | When the support arms are raised, the support arm lock must engage and remain securely locked in place under lateral load. |
| · Equipment clamps etc.  | The equipment must be in place, functional and not deformed.   |
| · Synchronisation cables | Check condition.   |

### 5.6 Warnings and symbols

All warnings are clearly visible on the lift to ensure that the user uses the device in a safe and appropriate manner.

The warning signs must be kept clean and replaced if they are damaged or missing. Please read the signs carefully and memorise their meaning for future use.



Instructions before use and safety instructions read carefully!

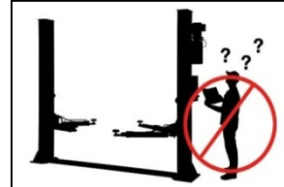

The lift may only be operated by qualified personnel!

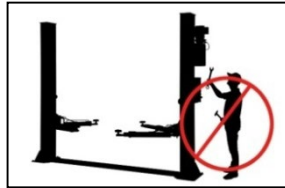

Repairs and maintenance may only be carried out by specialised personnel, never put safety devices out of operation!

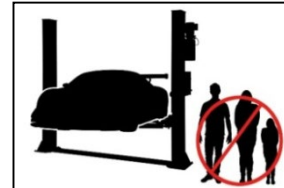

Specialist staff only permitted in the vicinity of the lifting platform!

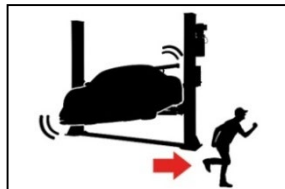

Escape routes always keep clear!



It is forbidden for persons to stand under the lift (when lifting or lowering)!

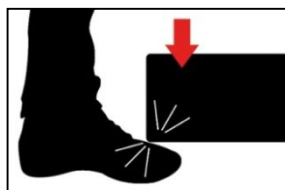

Take care of your feet! Crushing hazard!



Climbing on the lifting platform is strictly prohibited!



Observe the vehicle manufacturer's mounting points!

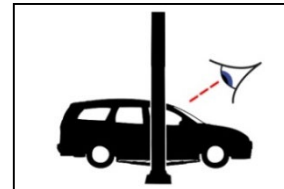

After briefly lifting the vehicle, check that it is securely seated!



Do not exceed the specified load capacity!

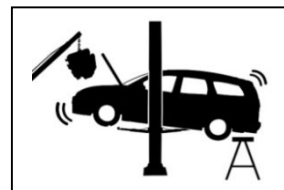

When installing or removing heavy parts can tip the vehicle!



Never attempt to load only one side of the lift!



Protect the lift from moisture! Electrical connections must be dry!



Strong shaking. Avoid damage to the vehicle.

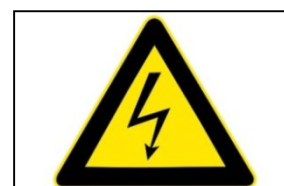

CAUTION! Electrical voltage!



### 5.7 Load distribution

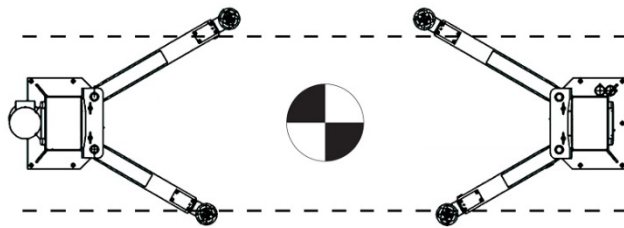
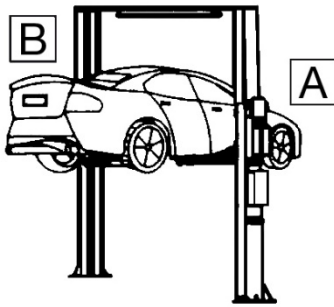

Lifting Capacity	Load distribution	
	B	A
3.6 T	1.5 T	2.1 T
4.2 T	1.9 T	2.3 T
5.0 T	2.5 T	2.5 T
6.0 T	3.0 T	3.0 T

## 6. Conformity with the product

The TW 242 GE 2-post lift is CE-certified and complies with the Machinery Directive 2006/42/EC and fulfils the standards EN 1493:2022, EN 60204-1:2018 (see under: EU Declaration of Conformity, at the end of the instructions for use).

## 7. Technical specification

### 7.1 General technical description

This lift consists of columns, a carriage, lifting arms, cylinders, a motor unit and other components. It is driven by an electro-hydraulic system. A gear pump delivers hydraulic oil to the oil cylinders and pushes the pistons upwards. The moving piston sets the chain in motion, which raises both the trolley and the lifting arms. During the lifting process, the safety pawl automatically and safely engages with the safety toothed block in the columns. This prevents slipping in the event of a hydraulic system failure.

#### Security structure:

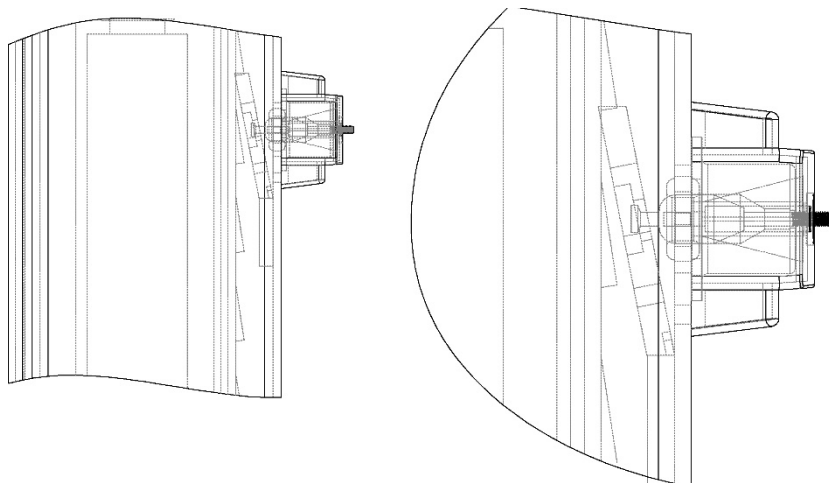

7.2 Machine description

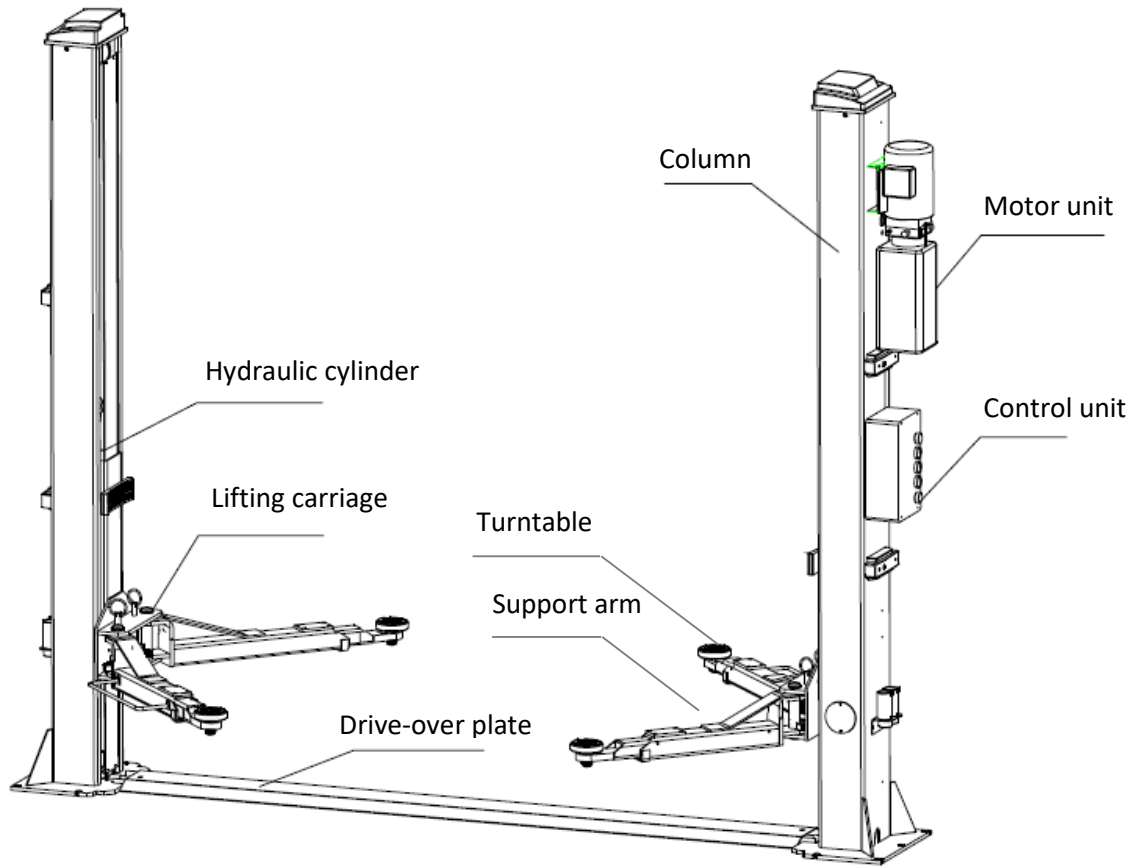

## 8. Installation

### 8.1 Before installation

#### 8.1.1 Tools and equipment required:

- Appropriate equipment
- Hydraulic oil HLP32
- Impact drill
- Spanner attachments and open-end spanners, a set of Allen keys, Phillips and slotted screwdriver
- Hammer, pincers, 17 mm, 19 mm, 22 mm socket spanner

#### 8.1.2 Checklist (packing list):

Unpack all parts and use Appendix 1 to check that each part is present. Do not hesitate to contact us if any parts are missing.

#### 8.1.3 Soil conditions and foundation

The lift should be installed on a smooth and solid floor with a compressive strength of more than 3 kg/mm<sup>2</sup>, a flatness of less than 5 mm and a minimum thickness of 200 mm.

In addition, a new concrete floor must rest for at least 28 days before a lifting platform can be installed. (See Appendix 2 for further information)

### 8.2 Precautions before installation

**8.2.1** Check that both columns are parallel to each other and vertical to the floor. Do not tilt.

**8.2.2** Check all hoses and connections.

The lift may only be put into operation if there are no leaks.

**8.2.3** All screws must be screwed tight.

**8.2.4** Do not place any vehicle on the lifting platform during a test run.

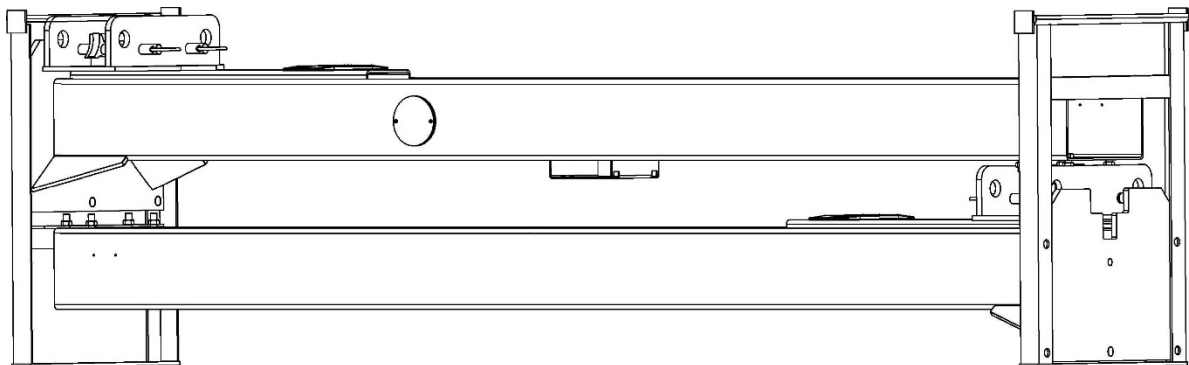

## 8.3 Structure

**Step 1:** Remove the packaging and take out the box containing the individual parts and cover plates. Read and understand the operating instructions before proceeding.

**Step 2:** Firstly, place a support between the two posts or lift one of the two posts using a suitably secure lifting device, then remove the screws from the frame. Draw the outline of the base plate on the floor with chalk and determine the position for the post.

**Caution:** **Please take particular care to ensure that the column cannot fall down. The accessories could be damaged or people could be injured.**

**Step 3:** After you have removed the first pillar, place a support under the other pillar. Then also remove the screws from the frame.

**Step 4:** Set up both columns. Align the main and secondary pillars at a distance of approx. 2500 mm (inside of the pillars).

1. After unpacking, you must decide which side you want to place the main column on. (the power connection and the control unit must be mounted on this). Set up the main column, place the floor cover plate on this column and determine the exact distance by erecting the second column and placing it on the second side of the floor cover plate.
2. **During the installation process, it is imperative that you ensure that none of the columns can tip over.**
3. Drill the holes in the floor for each floor anchor using a suitable percussion drill. Drill vertically. Carefully remove dirt and dust after drilling and make sure that the posts remain on the circle previously drawn with chalk.

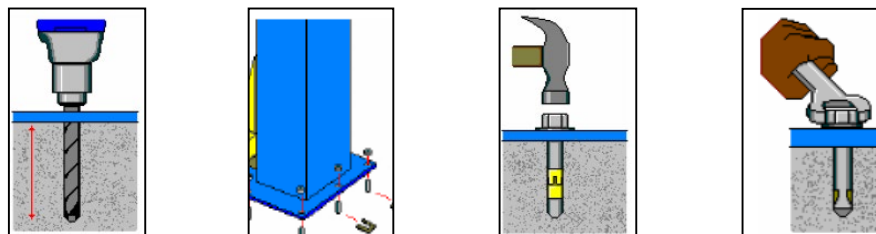
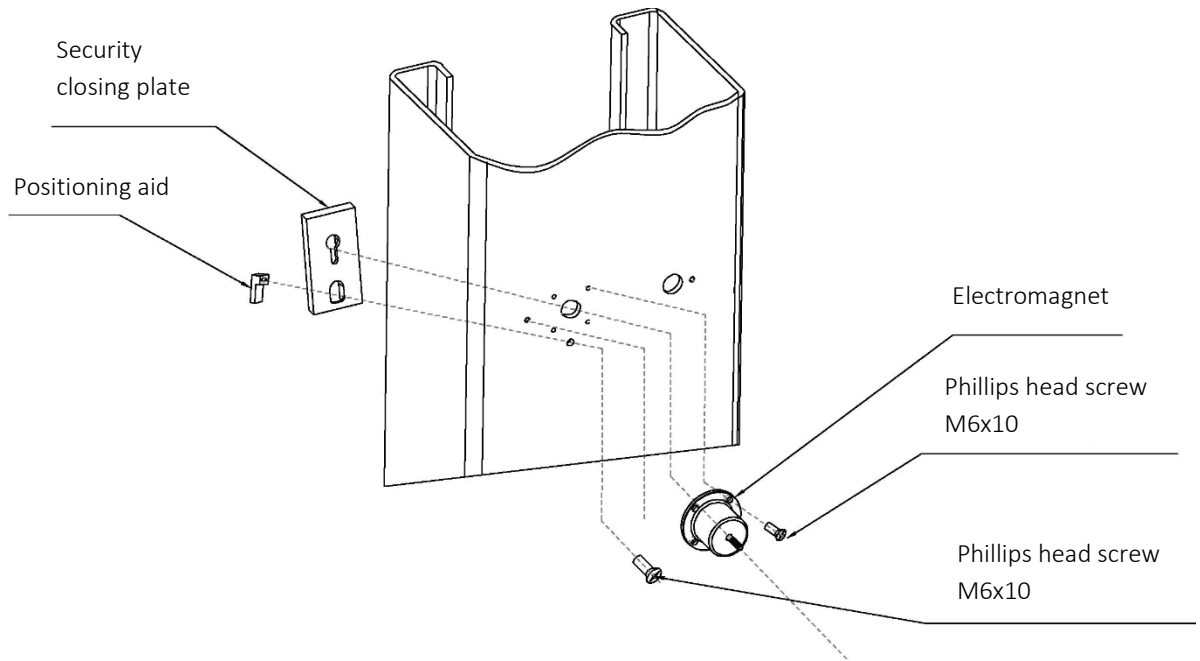
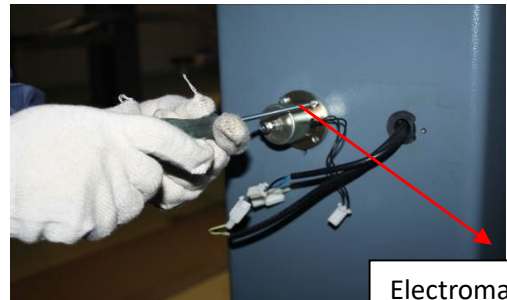

Figure: Work steps for fixing the pillars

**Step 5:** Attach the mechanical safety interlocks, and electromagnets, two to each column.



Safety interlock



Electromagnet

**Step 6:** Attach the base plate. Raise the two carriages by hand approx. 800 mm from the ground to lock them with safety latches and then place the base plate between two base plates of the columns.

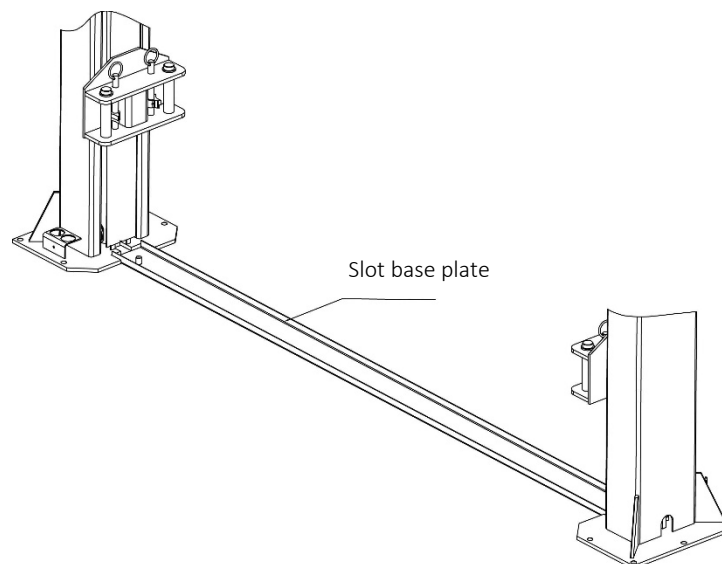

## Step 7: Install the steel cables.

1. Align the carriages on both sides approx. 800 mm above the floor.
2. Ensure that the safety catches on both columns are engaged before attempting to connect the ropes.
3. **The slides must be level with the ground before proceeding.**
4. Pull in the steel cables as shown in the illustration.
5. The steel cables must be set "taut" on both sides. Ensure that the sound of the safety latches can be heard equally on the right and left when lifting.
6. The ropes must be **secured (countered)** and oiled.

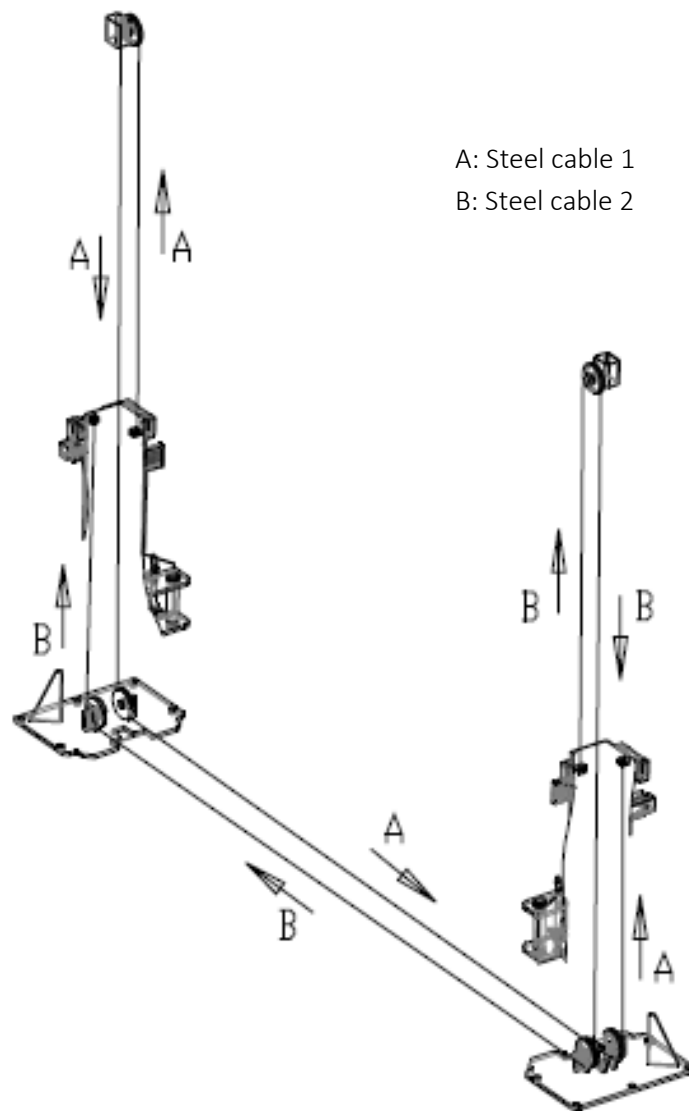

**Step 8:** Mount the motor unit

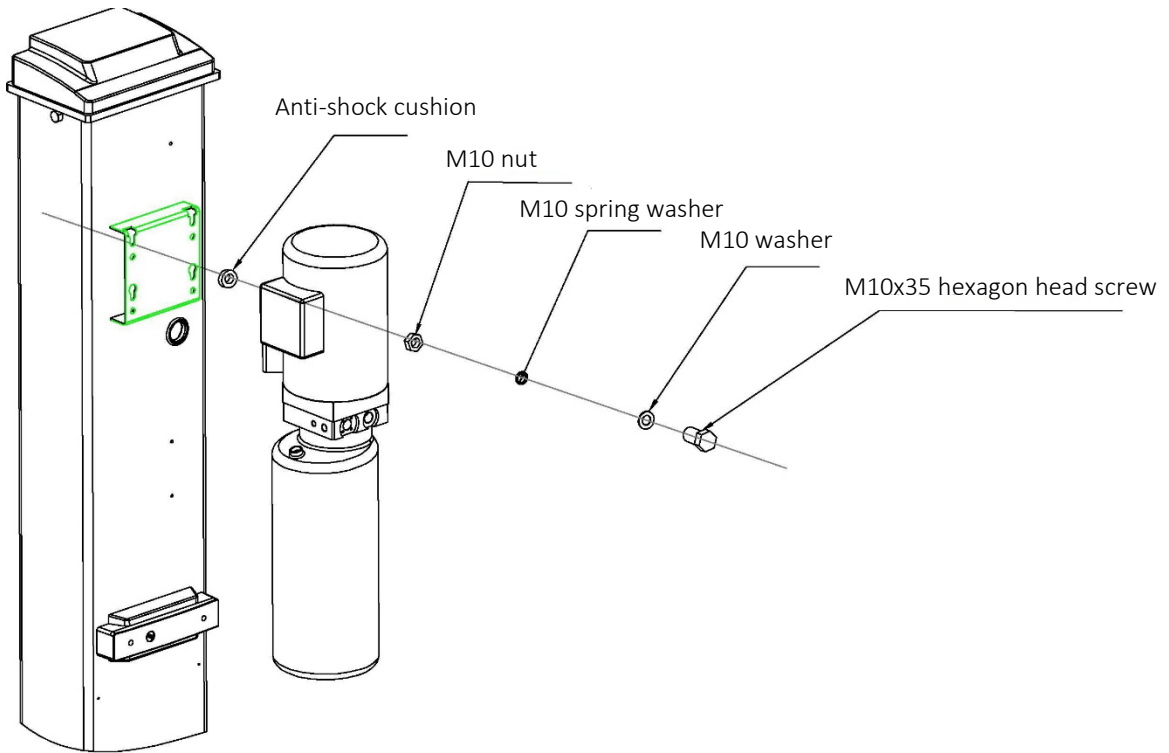

**Step 9:** Connect the oil hose as shown in the following illustration.

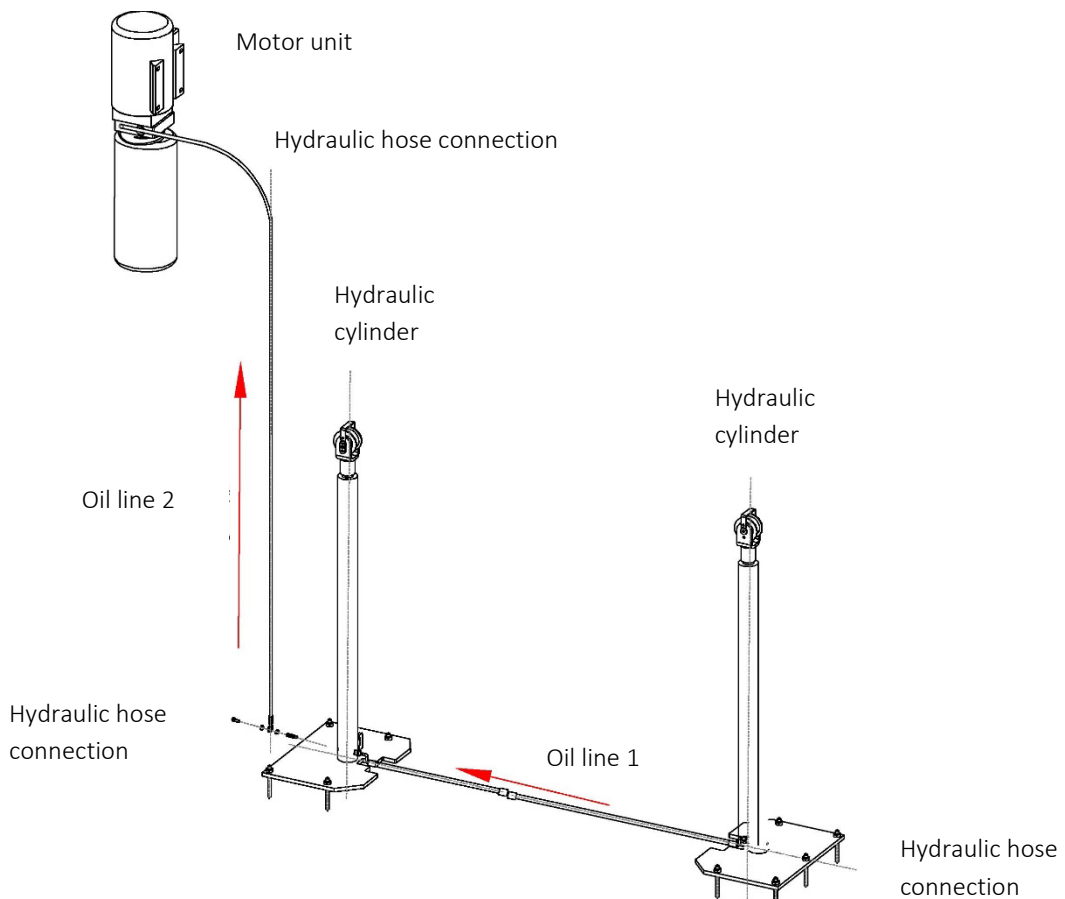

- a) Make sure that all hose ends are clean and free of dirt.
- b) Connect the hydraulic lines as shown in the following illustration or in the hydraulic circuit diagram.
- d) Fit the two steel cables to secure the pressurised hydraulic hose so that it is not thrown around uncontrollably.



### Step 10: Connect the cable.

1. Mount the switch box on the main pillar

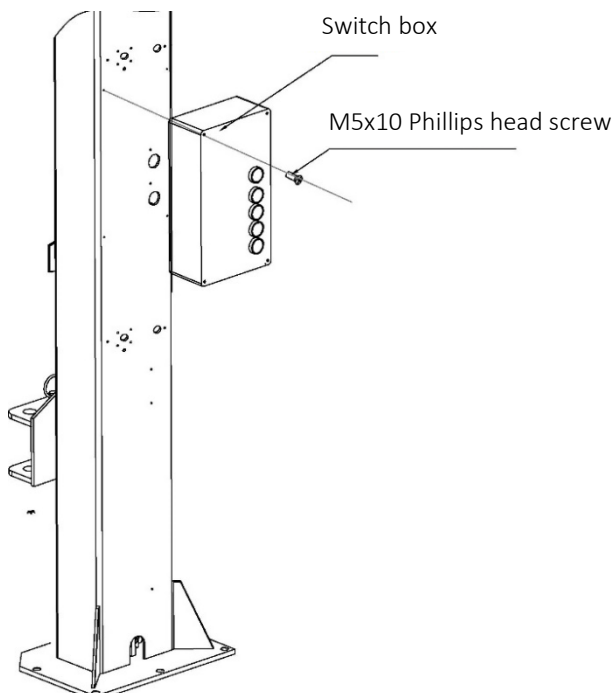



2. Connect the quick connector between the electromagnets.



Quick connector



Adjustable bolt

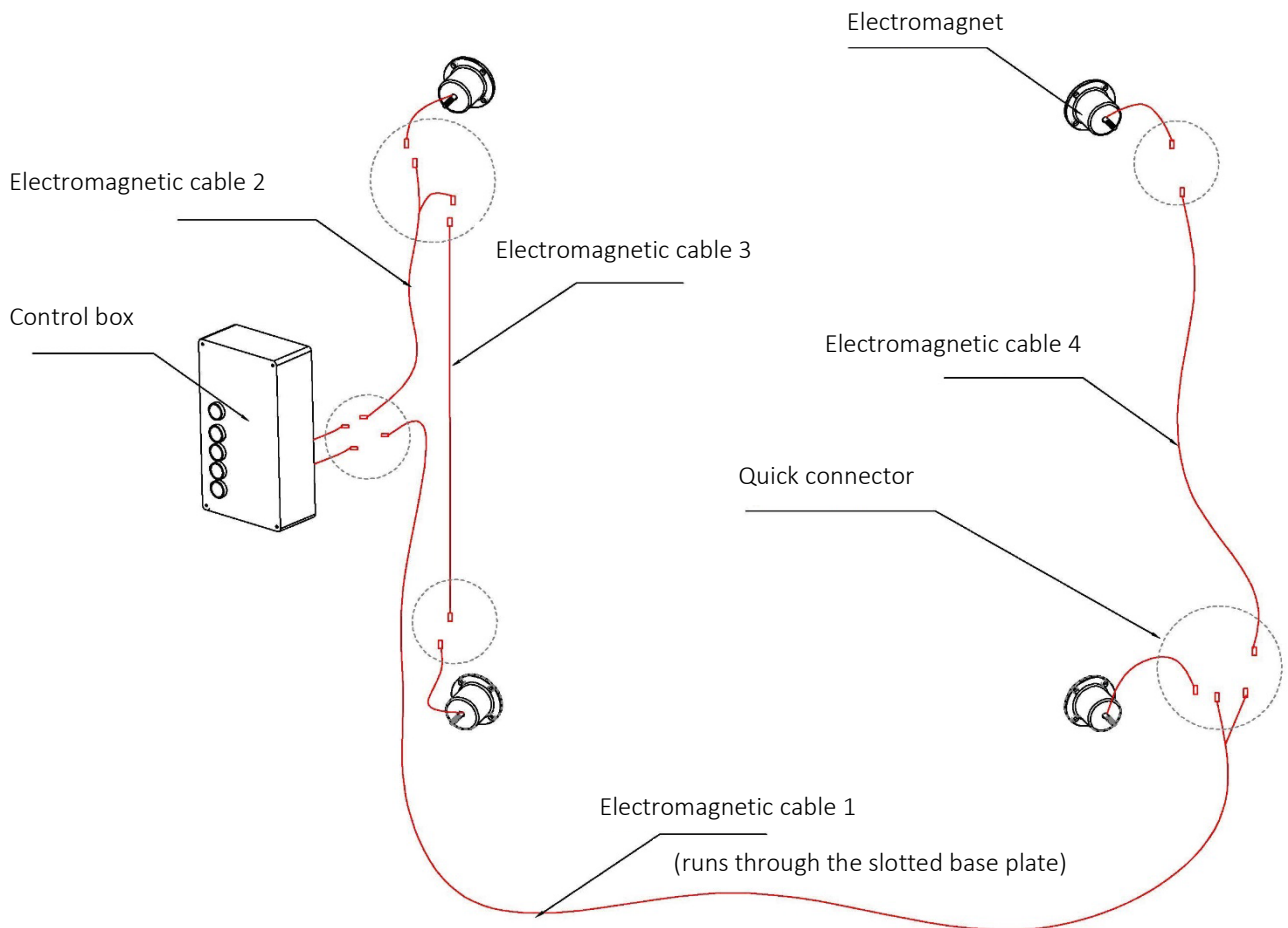

3. Connect the solenoid valve cable and the motor cable

**Step 11:** Attach the protective devices for cables and oil hoses.

**Step 12:** Assemble the support arms.

Insert the support arms into the carriage, paying attention to the interlocking of the safety blocks. Tighten the screws. Attach the support arms to the carriage and make sure that the arm lock can function.

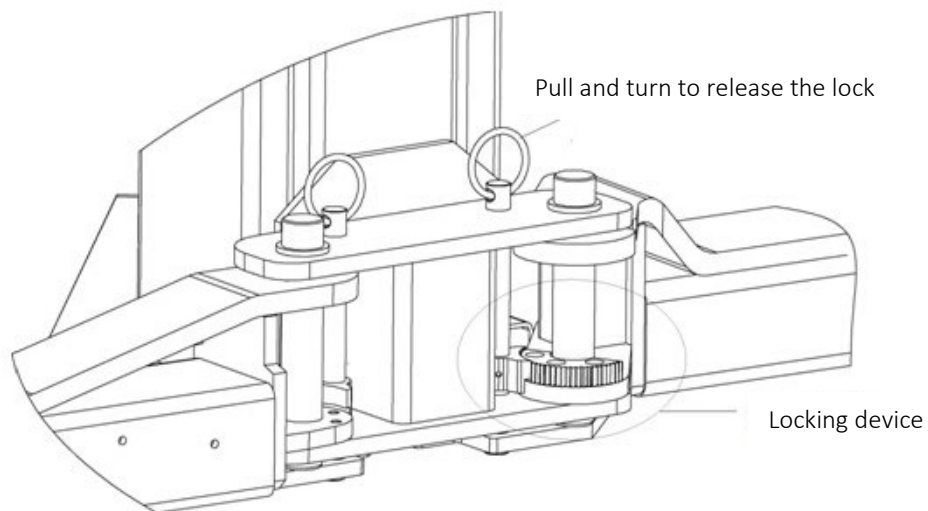
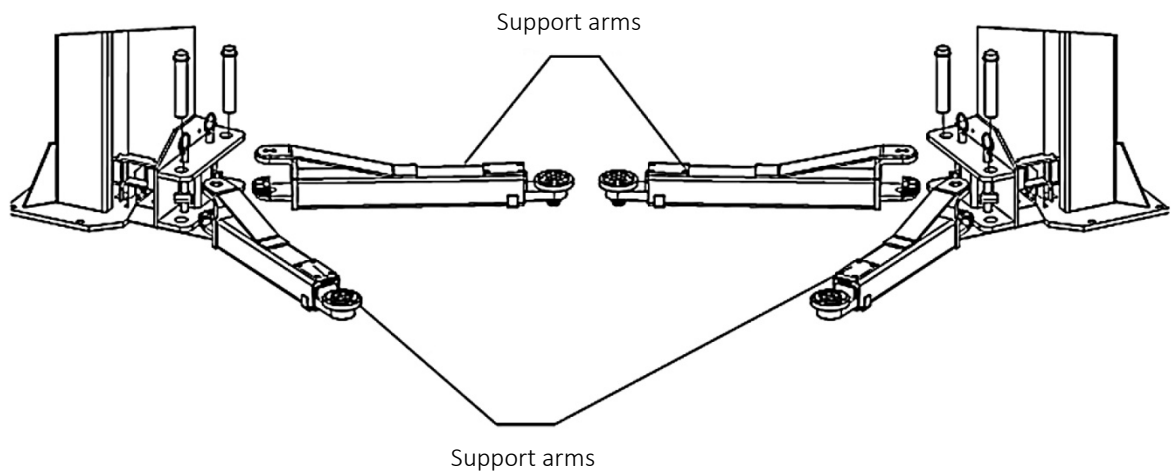

**Step 13:** Fitting the protective bracket.

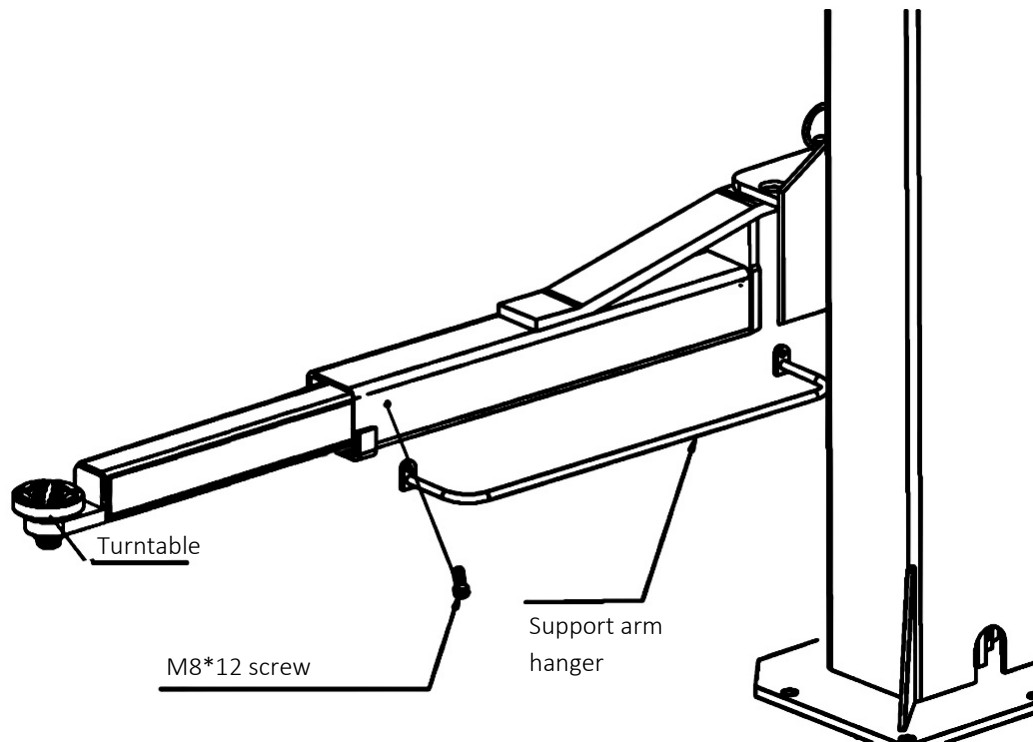

**Step 14:** Filling the hydraulic oil.

The oil tank has a capacity of 10 litres. To ensure that the lift works, you should fill the tank to 80 % with hydraulic oil (when the support arms are in the lowest position).

Hydraulic oil type: **HLP 32**.

**Step 15:** Test run.

1. Follow the operating instructions and ensure that no vehicle is on the lift during a test run.  
**No vehicle** may be on the lift during a test run.
2. Check the condition of all connections.

**Attention:** Please ensure that the support arms are swivelled in / folded inwards to prevent collision with the oil tank.

**Note:** If no support arms have been fitted and/or it is very cold, the carriages will only lower very slowly. Under load, the lowering speed is normal.

**Step 16:** Fit the overrun plate and the door stop protection

Attach the drive-over plate, the chain guards, the protective covers for the electromagnet and the guards for the door openings.

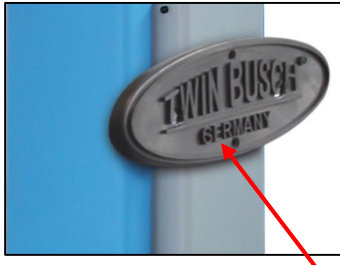

Door stop

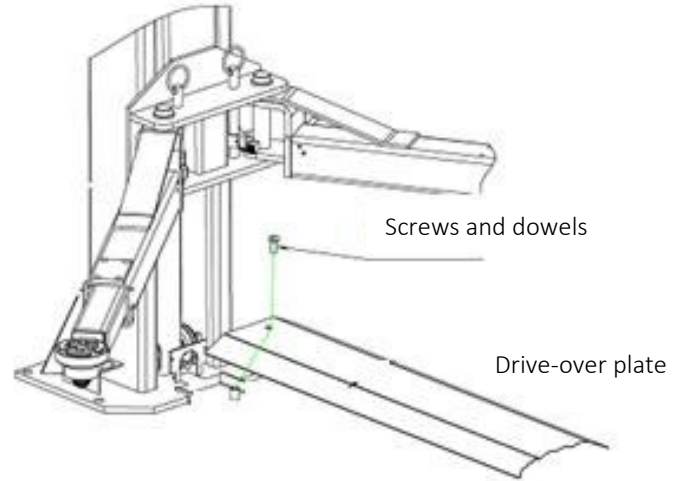

Screws and dowels

Drive-over plate

**8.4 Checkpoints after installation.**

S/N	Check	YES	NO
1	Are the columns vertical to the floor? (90°)		
2	Are the two columns parallel to each other?		
3	Is the oil hose connected correctly?		
4	Is the steel cable correctly and firmly connected?		
5	Are all support arms correctly and firmly fitted?		
6	Are the electrical connections correct?		
7	Are the joints all screwed tight?		
8	Have all parts that need to be greased been greased?		

## 9. Operating instructions

### 9.1 Safety precautions

- 9.1.1 Check all connections of the oil hose.  
If there are no leaks, the lifting process can be started.
- 9.1.2 If the safety devices fail, the lift must not be used!
- 9.1.3 If the vehicle's centre of gravity is not in the middle, the lift must not be started up or shut down. Otherwise, neither we nor the dealer will accept responsibility for any problems or damage caused.
- 9.1.4 Users and other employees involved should stand in a safe area during the lifting process.
- 9.1.5 When the carriers have reached the desired height, switch off the power to avoid incidents. Avoid incidents triggered by bystanders.
- 9.1.6 Ensure that the safety catches are engaged before starting work under the vehicle. No persons may be under the vehicle during the lifting and lowering process.

### 9.2 Flow chart

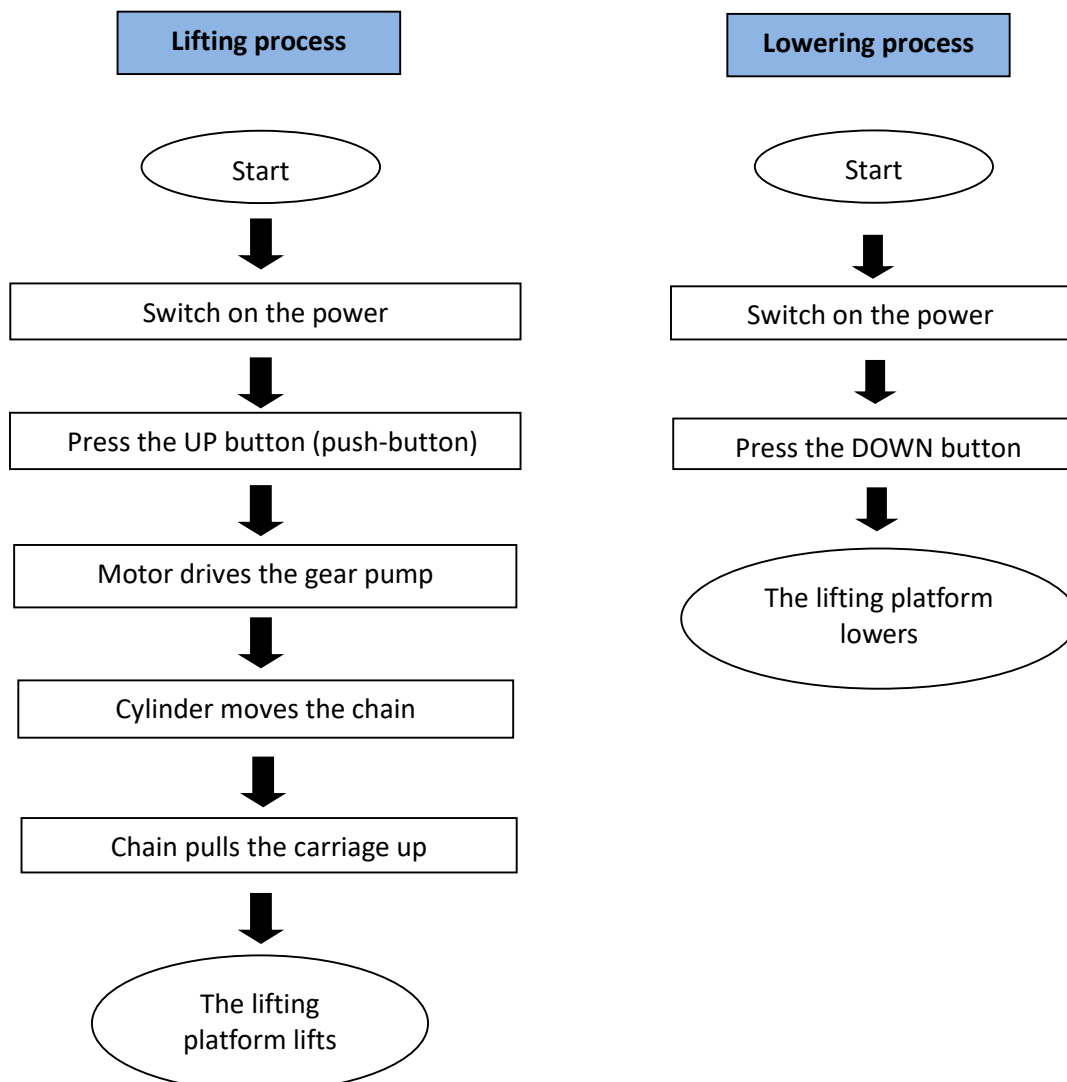

### 9.3 Operating instructions (lifting and lowering process)

*Lifting process:*

- 1 Read and understand the operating instructions before starting work.
2. Park the vehicle between the two pillars.
- 3 Align the lift so that the pick-up points on the vehicle are in line with the lift. Make sure that the vehicle is positioned correctly.
- 4 Switch on the lift and press the UP button on the control box until the support arm mount touches the vehicle at the point approved by the manufacturer.
5. press the button until the vehicle is raised by about 10-15 cm. Now stop the lifting process and make sure that the vehicle is correctly and securely supported.
- 6 After final alignment and checking for correct fit, press the UP button again and hold it down until the desired height is reached. Press the safety lock button on the control panel to activate the safety lock. Now switch off the power and then carry out maintenance or repair work underneath.

*Lowering process:*

1. Switch on the power.
2. Press the "DOWN button" on the control unit. The lifting arms now automatically move upwards by about 5 cm, which releases the safety lock. The lift lowers.
3. After the carriers have been moved to the lowest position, swivel the support arms out from under the vehicle.
4. Clear all obstacles out of the way and remove the vehicle.

### 9.4 Description of the switch box



Description	Function
Main switch	Switch on or off
Operating light	Indicates whether there is a power supply
UP button	Raising the lifting platform
Button for the safety lock (Safety Lock)	Ensuring safety in the operating process
DOWN button	Lowering the lifting platform
Emergency stop	Switches the system off in an emergency

## 10. Operating instructions

**CAUTION:** Do not hesitate to contact us if you are unable to rectify the fault yourself.

We will help you as quickly as possible. If you send us a detailed description of the fault or pictures, we can recognise and rectify the problem more quickly.

PROBLEMS	CAUSE	SOLUTION
Unusual noise.	Wear on the inner sides of the pillars.	Grease the inside of the pillars.
	Contamination in the columns.	Remove the dirt.
The engine cannot be started, nor does the lift move up.	The cable connections are loose.	Check the cables and reconnect them.
	The motor is defective.	Replace it.
	The limit switch is defective/damaged or the cable connection is loose.	Reconnect the cables or replace the limit switch.
Engine runs, but does not raise the lift.	The motor runs in reverse.	Check the cable connection.
	The pressure relief valve is loose or dirty.	Clean or screw it tight.
	The gear pump is defective.	Replace them.
	The oil level is too low.	Top up with oil.
	The oil hose has come loose or is torn off.	Fasten or replace it.
	The damping valve is loose or jammed/blocked.	Clean or fasten it.
The beams lower slowly after they have been raised.	The oil hose is leaking.	Check or replace it.
	The oil cylinder/piston is leaking.	Replace the seal.
	The directional valve is leaking.	Clean or replace it.
	The solenoid valve is not working properly.	Clean or replace it.
	Steel cable is loose or not evenly tensioned	Check and adjust it
Lifting too slowly.	The oil filter is dirty or jammed.	Clean or replace it.
	Oil level is too low.	Top up with oil.
	The pressure relief valve is incorrectly adjusted.	Adjust it correctly.
	Incorrect hydraulic oil (viscosity)	Only use HLP 32.
	The cylinder seal is worn.	Replace the seal.
	The inner surface of the posts is not well greased.	Add grease.
	The hydraulic oil is too hot (over 45°).	Change the oil.
Lowering too slowly.	The throttle valve is jammed/dirty.	Clean or replace it.
	The hydraulic oil is contaminated.	Change the oil.
	The drain valve is blocked.	Clean it.
	The oil hose is damaged/kinked.	Replace it.
The steel cable is worn.	Not greased during installation or it is worn.	Replace it.

## 11. Maintenance

Simple and inexpensive regular maintenance can guarantee you a long and safe use of the lift. The following are suggestions for regular maintenance. How often you service your lift depends on how often you use it.

The following points must be lubricated:

S/N	Description
1	Upper pulley
2	Steel cable
3	Sprocket wheel
4	Chain
5	Sledge
6	Pen
7	Safety blocks
8	Support arm
9	Turntable holder
10	Lower pulley

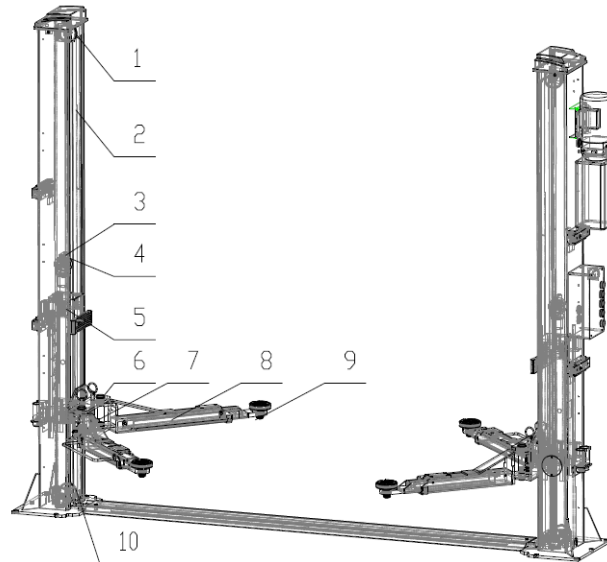

### 11.1 Daily inspection of parts before operation

It is very important to check the safety functions daily before using the lift! Detecting a device failure before use will save you time, major damage or even injury.

- Before use, check whether the safety catches are working by listening to the sound.
- Check whether the oil hose is well connected and whether it is tight.
- Check the connection between the chain and the steel cable and check the power source.
- Check that the floor anchors are firmly screwed in place.
- Check the support arm lock.

### 11.2 Weekly inspection of the parts

- Check the mobility of the flexible parts.
- Check the condition of the safety device.
- Check the oil level. The oil level is good if the carriage can be moved to the highest position. Otherwise, the oil level is too low.
- Check that all screws are tight.

### 11.3 Monthly inspection of the parts

- Check that the screws are tight.
- Check carriages, arm bolts, support arms and other related parts for wear and lubricate them.
- Check the lubrication and condition of the steel cable.



## 11.4 Annual inspection of the parts

- Empty and clean the oil tank and replace the hydraulic oil.
- Replace the oil filter.

If the user follows the maintenance suggestions above, the lift will remain in good condition and accidents can continue to be avoided.

## 12. Behaviour in the event of a malfunction

If the lift malfunctions, simple faults may be the cause. Use the following list for troubleshooting \*).

If the cause of the fault is not listed or cannot be found, please contact the expert Twin Busch GmbH team.

***Never attempt to carry out repairs yourself, especially on safety equipment or electrical system components.***

\*) Points depending on the design and type of lift





**Work on electrical systems only by qualified electricians!**

**Problem: Lift can neither be raised nor lowered.**

### Possible causes

- No power supply available.
- Power supply interrupted.
- Main switch not switched on or defective.
- Emergency stop pressed or defective.
- Fuse in the power connection has tripped or is defective.
- Fuse in the switch box has tripped or is defective.

### Remedy



- Check power supply.
- Check power supply line.
- Check main switch. 
- Unlock emergency stop, check. 
- Check fuse.
- Check fuse.

**Problem: Lifting platform cannot be raised.**

### Possible causes

- For three-phase current: one phase missing.
- With three-phase current: Direction of rotation of motor reversed.
- Oil pump defective.
- Motor is defective.
- Overload.

### Remedy

- Check power supply. 
- Check direction of rotation, swap phase if necessary 
- Notify Twin Busch Service.
- Notify Twin Busch Service.
- Overload valve has opened, reduce load.

**Problem: Lift cannot be lowered.**

### Possible causes

- Lifting platform sits in safety catches.
- Lift has run into limit switch.
- Motor is defective.
- Lift has been blocked during lowering.

### Remedy

- Raise platform slightly, pull detents, lower.
- If necessary, release limit switch, raise 1 cm and lower.
- Open the safety latch and raise the lift
- lower emergency lowering.
- Raise the lift again slightly and remove the obstacle.

### 13. Appendix

#### 13.1 Packing list for the lift

S/N	Material	Name	Licence plate number	Description	Quantity
1		Main column assembly	FL-8224SE-A1	Assembly	1
2		Secondary column	FL-8224SE-A2	Assembly	1
3		Mounting the slide	FL-8224SE-A3	Assembly	2
4		Aggregate		Assembly	1
5		Oil cylinder	FL-8224T-A4-B3	Assembly	1
6		Drive oil cylinder	FL-8224T-A4-B2	Assembly	1
7		Electrical system		Assembly	1
8			Switch box		1
9			Wire package		1
10		Steel cable L=7470 mm	FL-8224-A6	Assembly	2
11		Long arm	FL-8224-A7	Assembly	2
12		Short arm	FL-8224-A8	Assembly	2
					1
14		Floor cover plate	FL-8224T-A10	Powder coating	1
Carton (contains the following )					
17		Column cover	FL-8224E-A1-B6	ABS	2
18		Support arm bolts	FL-8224 -A12	Galvanisation	4
19					
20		Short foot guard	FL-8224 -A8-B4	Powder coating	2
21		Long foot guard	FL-8224-A7-B4	Powder coating	2
22		Mounting the lifting shell	FL-8224 -A7-B3	Assembly	4
23		Rubber oil hose L=2265 mm		Assembly	1
24		Rubber oil hose L=2900 mm	8224E-B4-B2	Assembly	1
25		Safety locking plate	FL-8224E -A1-B2	Galvanisation	
26					
27		Positioning block	FL-8224E -A1-B3	Galvanisation	
28		Hose and wire cover	FL-8224E -A1-B8	Powder coating	6
29		Chain protection cloth	FL-8224 -A11	Assembly	2
30		Mounting column protection cover	FL-8224 -A13	Galvanisation	4
31		Rubber protective pad	FL-8224 -A3-B7	Rubber	2
32		Nylon washer	FL-8224 -A17	Rubber	10
33					
34		Union nut with hexagon head	M8*35	Standard	4
35		Allen screw with hexagon socket	M8*12	Standard	8
36		Phillips head screw	M6*10	Standard	28
37		Phillips head screw	M6*25	Standard	12
38		Phillips head screw	M6*16	Standard	4
39		Phillips head screw	M8*16	Standard	4
40		Washer class C	M6	Standard	8
41		Washer class C	M8	Standard	4
42		Spring washer	M8	Standard	4
		Hexagon nut	M6	Standard	8
		Hexagon nut	M8	Standard	4
		Circlip type B	38	Standard	4
		Fixing anchor	M16*180	Standard	10

13.2 General diagram

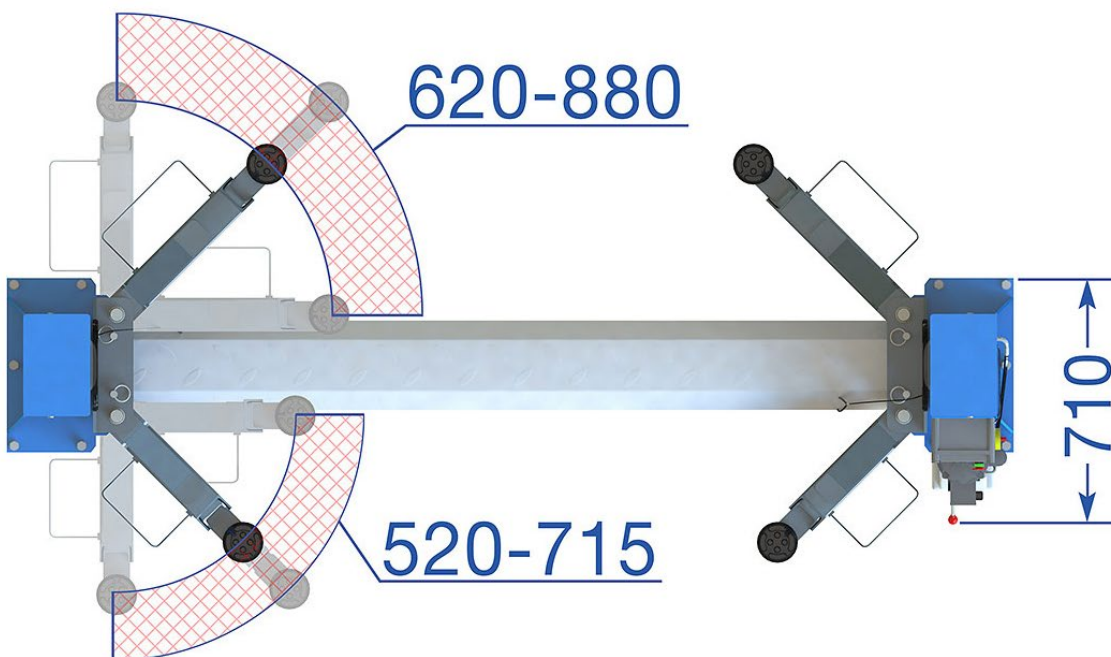
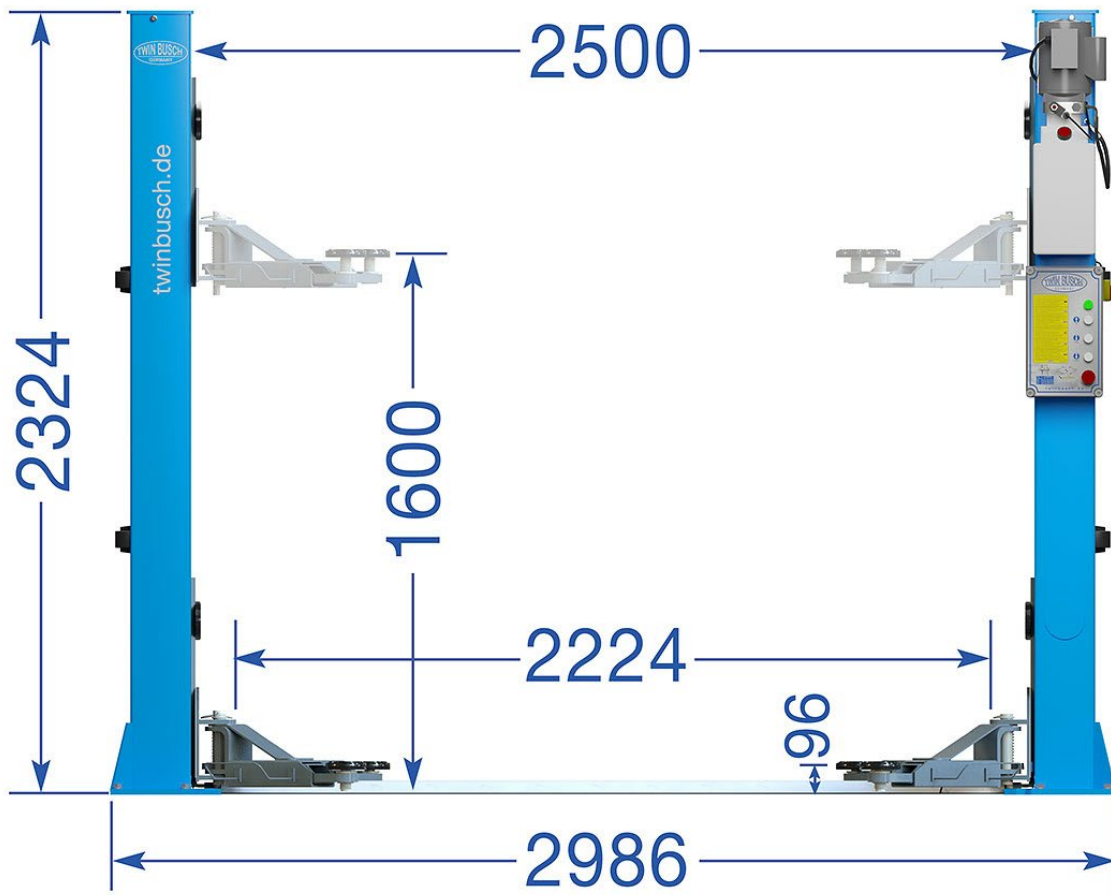

13.3 Diagram for floor fastening / foundation plan

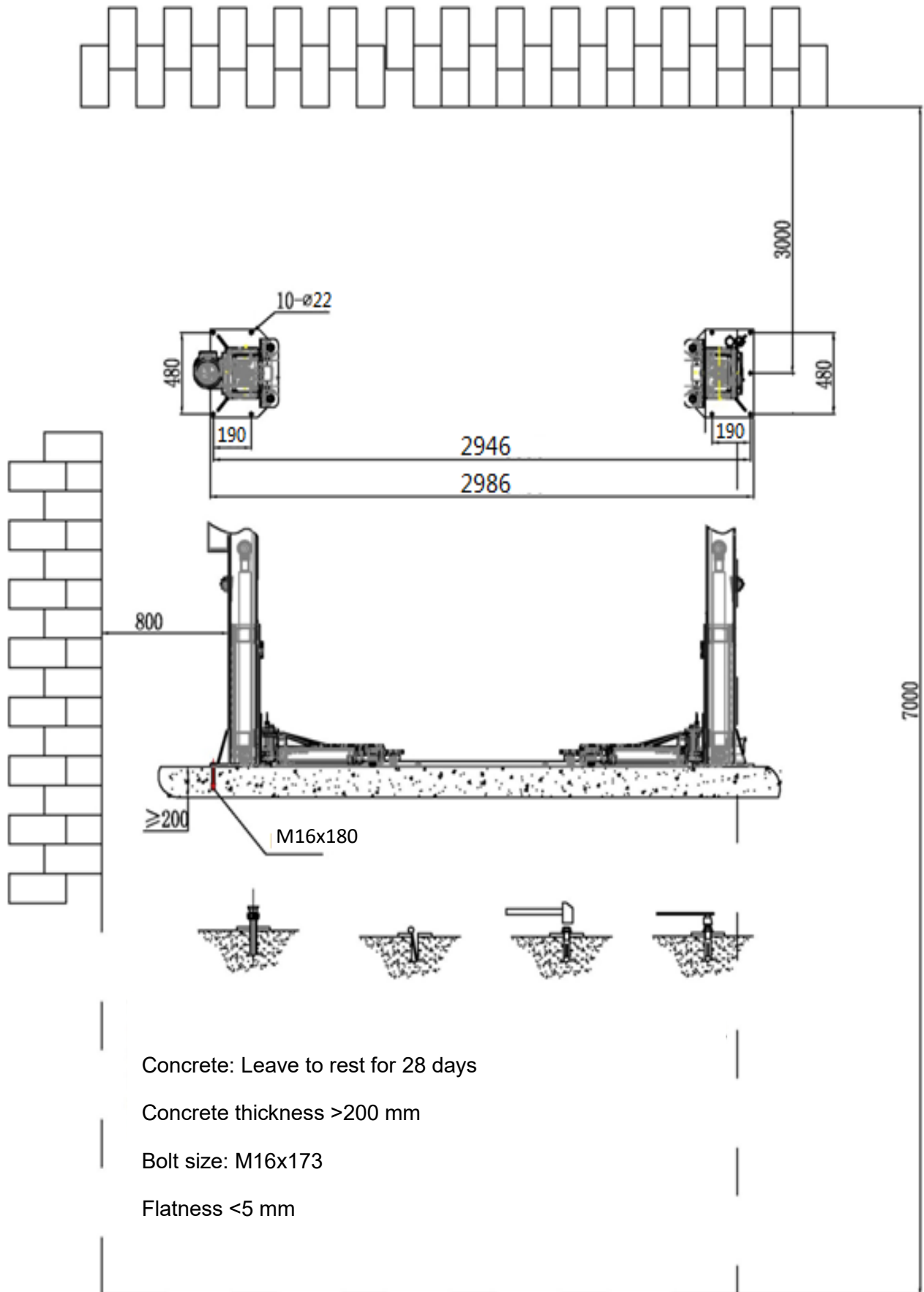

### Concrete requirements:

In accordance with the DIN 1045-2 and DIN EN 206-1 standards, concrete with the designation C20/25 (old standard: B25) is produced. This concrete is composed of CEM II 32.5 in accordance with EN-197-1 as a binder, a grain size group of 0/22, whereby the grain size is in the range from 0 to 22 mm, and a maximum grain size of 22 in accordance with DIN EN 12620.

The substrate requirements for the application of this concrete are that the floor must be level and the evenness of the floor must not exceed 5 mm over the entire surface.

After the concrete has been applied, it is necessary for it to rest for a period of 28 days to ensure optimum strength and structure. This rest period is crucial for the hardening of the concrete and the development of its mechanical properties.

### Foundation dimensions:

Ideally, the entire hall floor in C20/25 concrete, 200 mm (up to 4.2 tonnes) or 250 mm thick (5 tonnes).

### Minimum dimensions:

2-columns up to 4.2 t: 4 m x 3 m x 0.2 m

### Width for TW242GE:

3.6 m is sufficient instead of 4 m, but min. 3.3 m

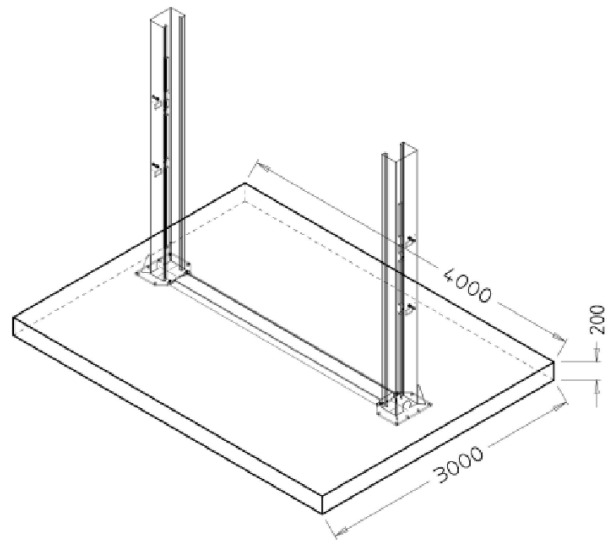

### Alternatively H-shaped (TW242GE width 3.6 m)

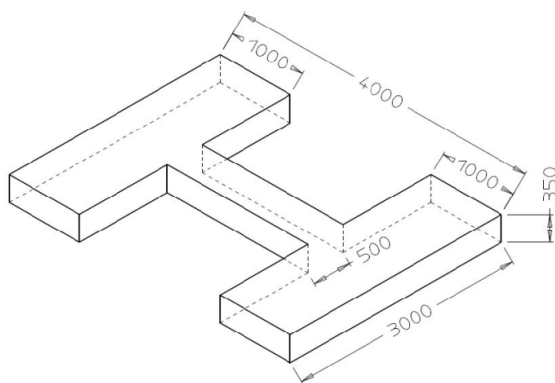

### Alternative blocks (TW242GE width 3.6 m)

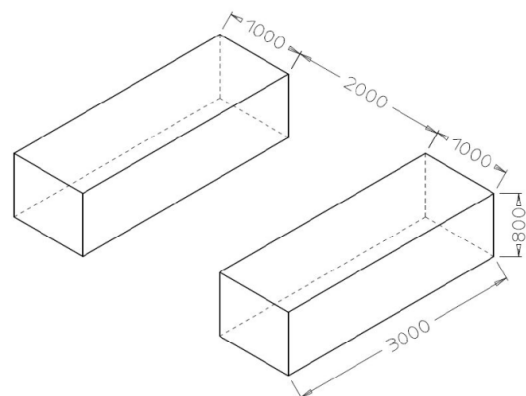

## Other requirements:

- The surrounding soil must be suitable for the load, e.g. no sandy soils, etc.
- Reinforcement of the concrete is only not necessary for the lifting platform if it is used properly.
- If in doubt, the foundation should always be determined/checked by a structural engineer.

## The following must be observed for soil exposed to frost:

For frost exposure, the concrete must correspond to exposure class XF4, as dripping de-icing agent cannot be ruled out. This results in the following minimum requirements for concrete exposed to frost:

Exposure class:	XF4
Maximum w/c:	0,45
Minimum compressive strength:	C30/37 (instead of C20/25)
Minimum cement content:	340 kg/m <sup>3</sup>
Minimum air void content:	4,0 %

However, it must be noted that the lifts are not designed for outdoor use. Although the control box complies with IP54, the rest of the electrics, motors and limit switches have a maximum IP44 rating.

## Anchor bolt fastening

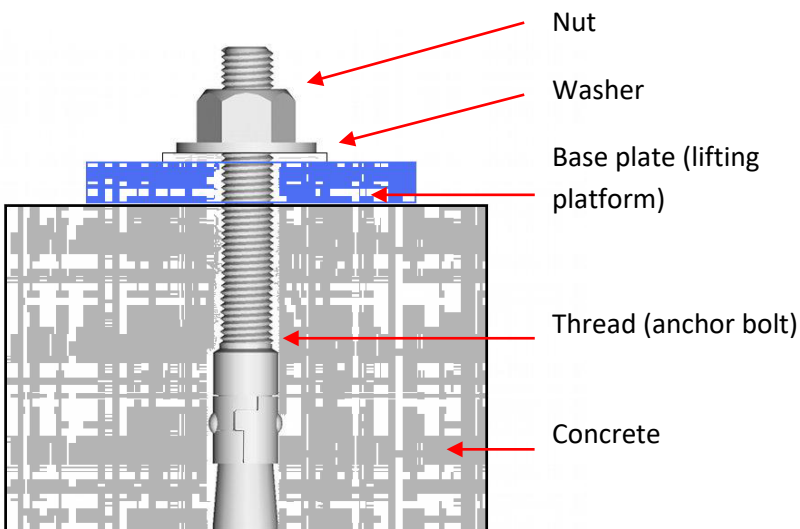

The anchor bolts (M16x173) are tightened to 110 Nm.

13.4 Hydraulic system

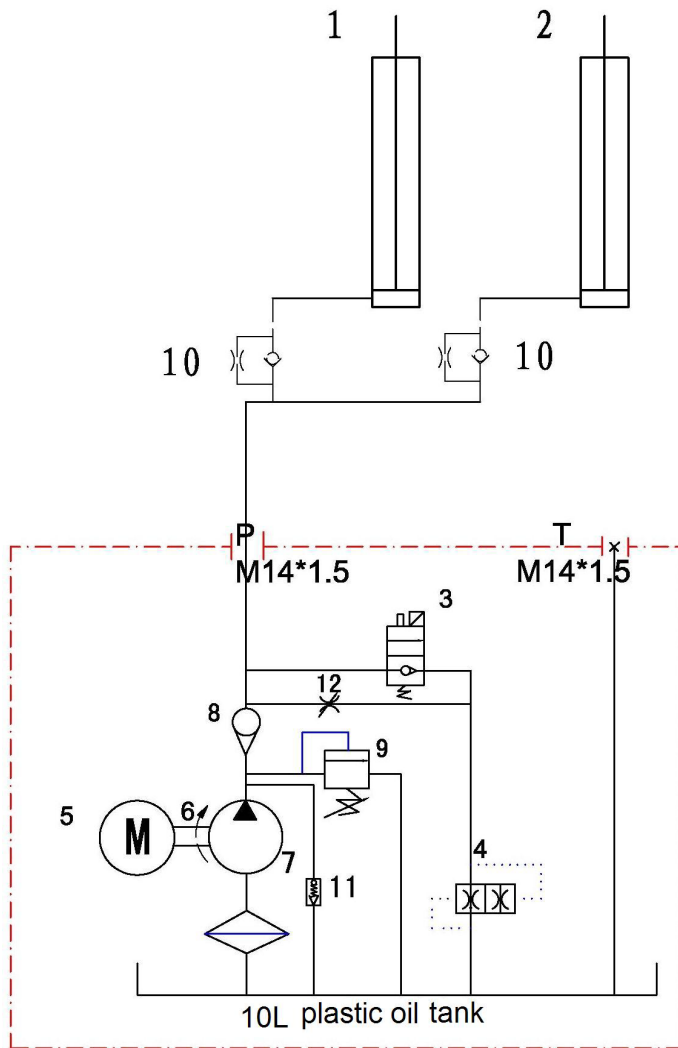

1. Master cylinder
2. Secondary cylinder
3. Manual pressure release valve
4. Throttle valve (adjustable)
5. Engine
6. Connection
7. Gear pump
8. Directional valve
9. Pressure relief valve
10. Throttle valve
11. Damping valve

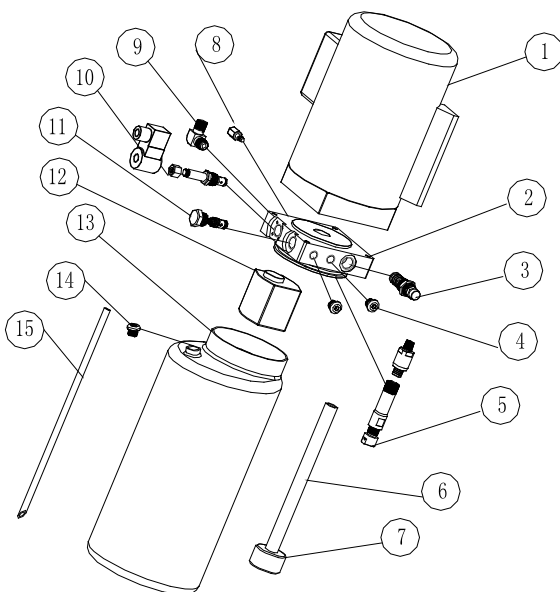

S/N	Name	Quantity
1	Motor	1
2	Hydraulic block	1
3	Pressure relief valve	1
4	Screw plug	2
5	Pressure regulating valve	1
6	Oil suction pipe	1
7	Oil filter	1
8	Throttle valve	1
9	Connection	1
10	Electromagn. drain valve	1
11	One-way valve	1
12	Gear pump	1
13	Plastic oil tank	1
14	Oil tank plug	1
15	Oil return line	1

### 13.5 Circuit diagrams

Single-phase:

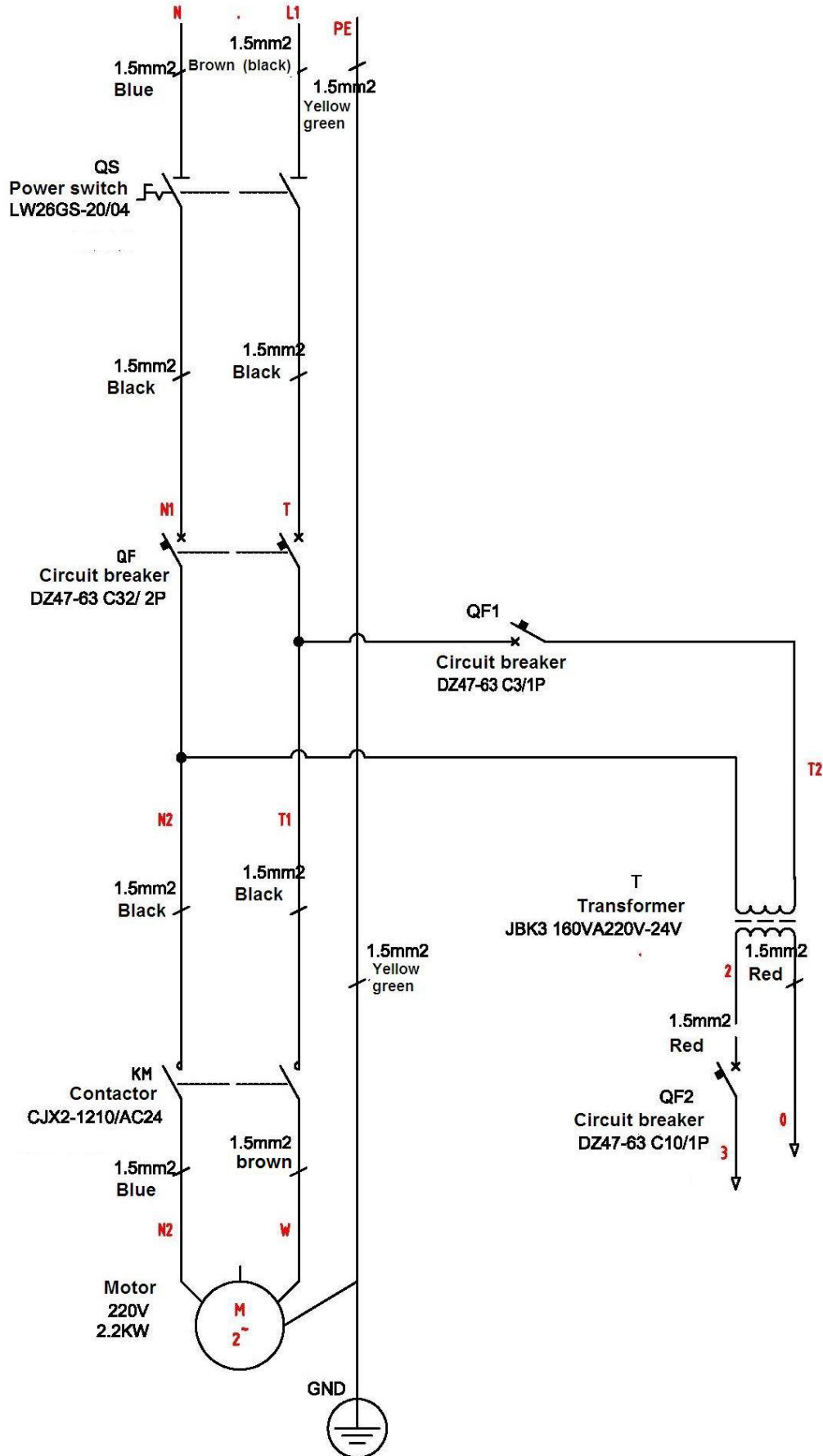



Three-phase:

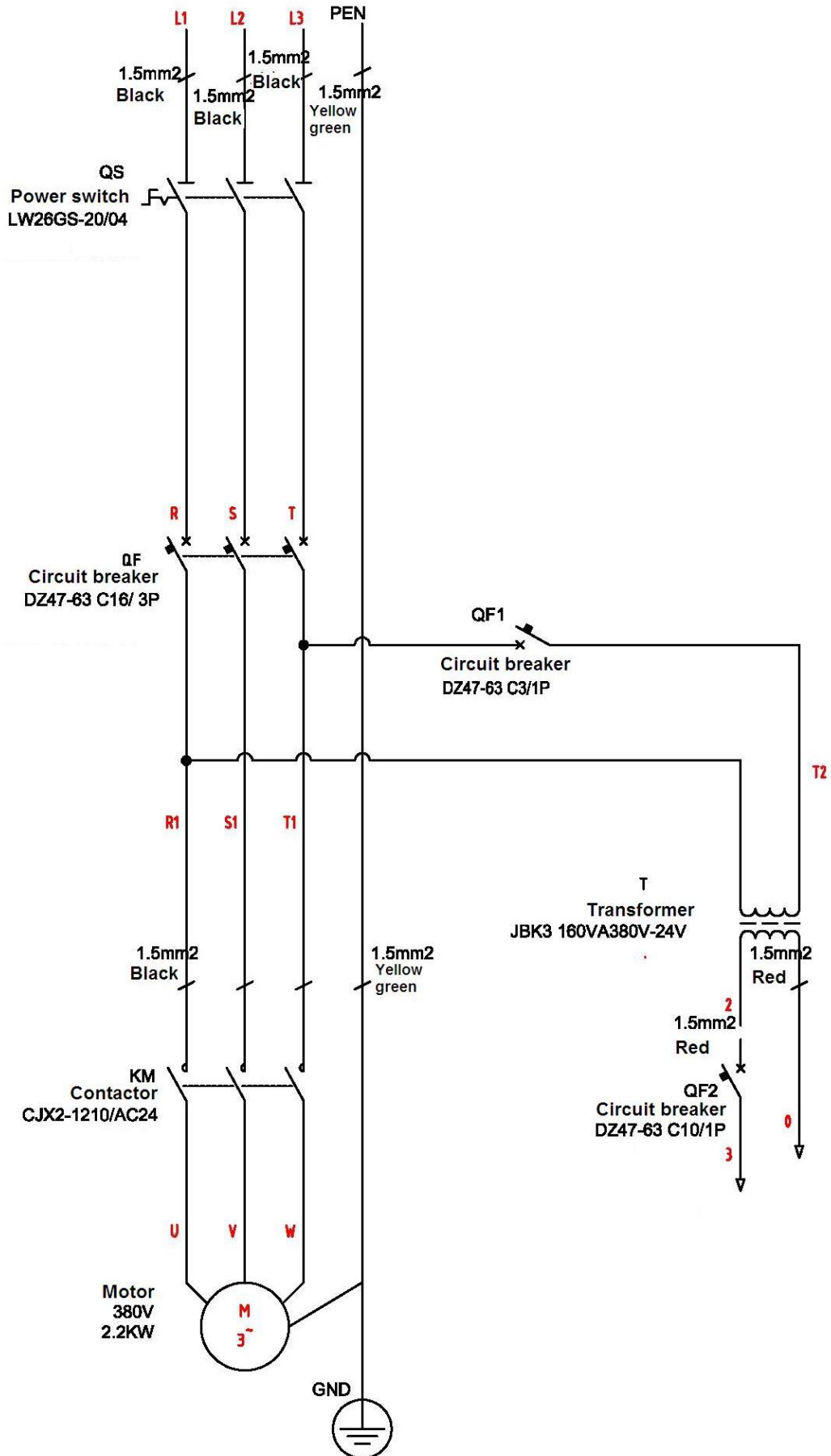

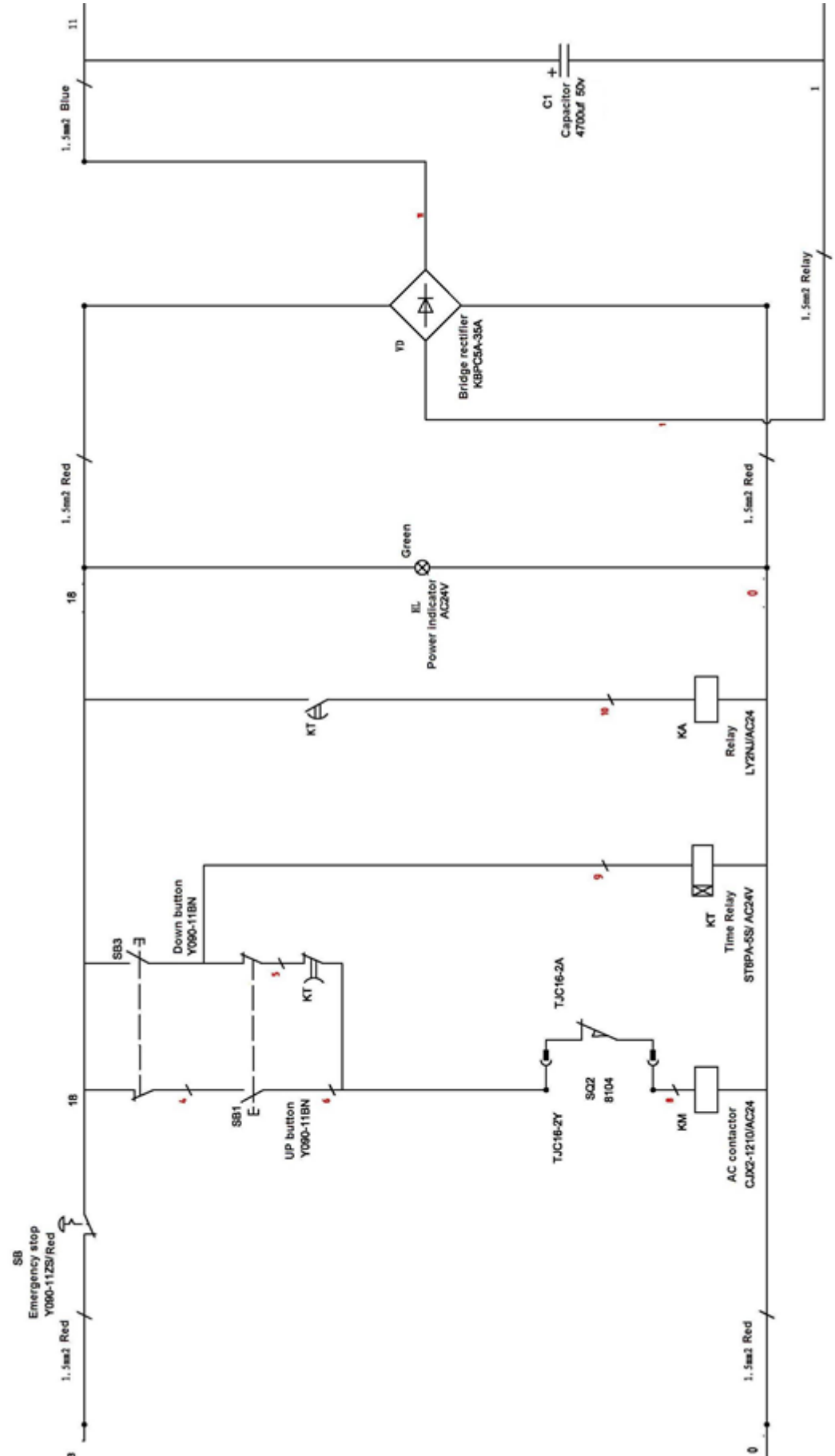

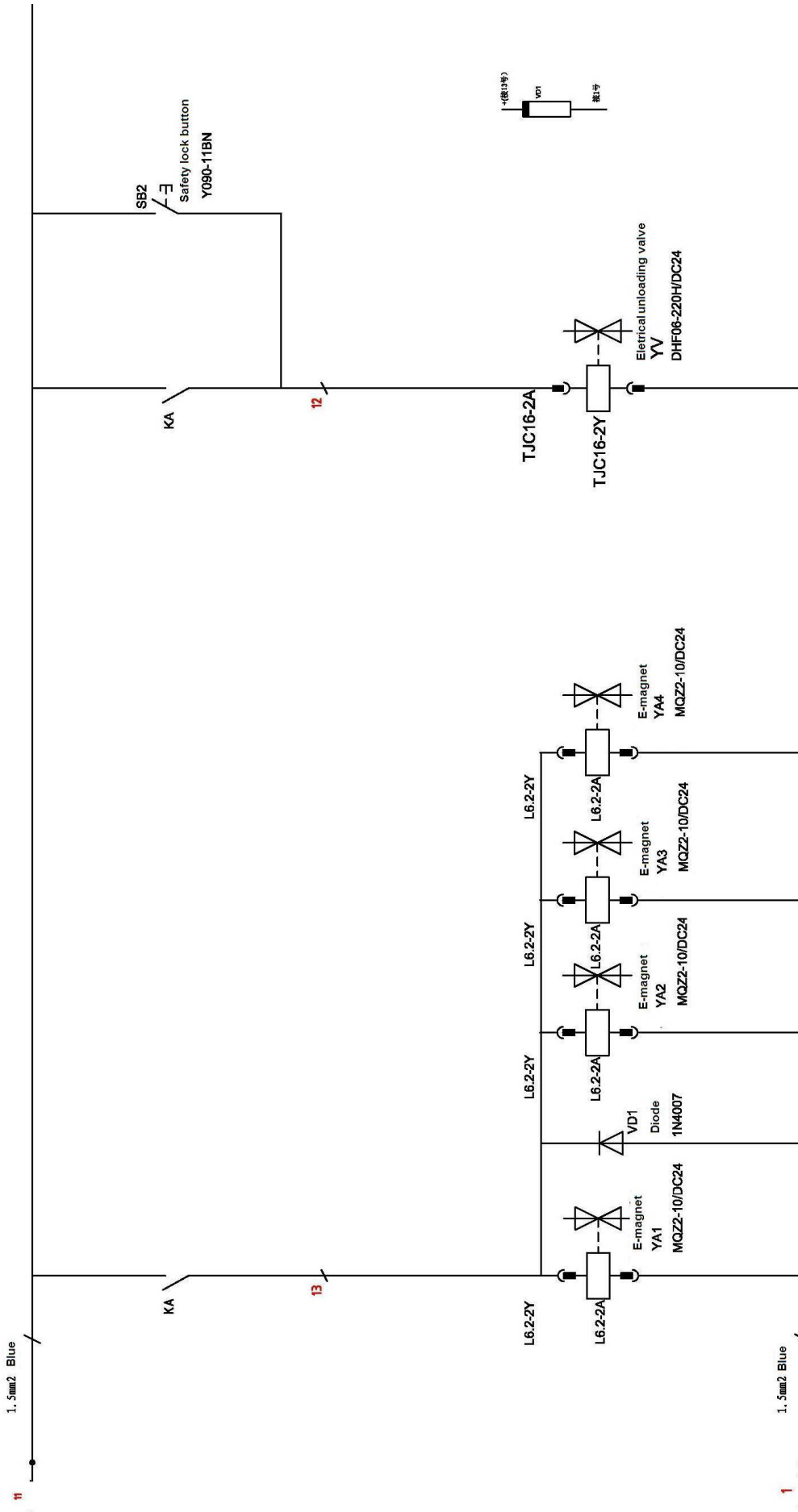

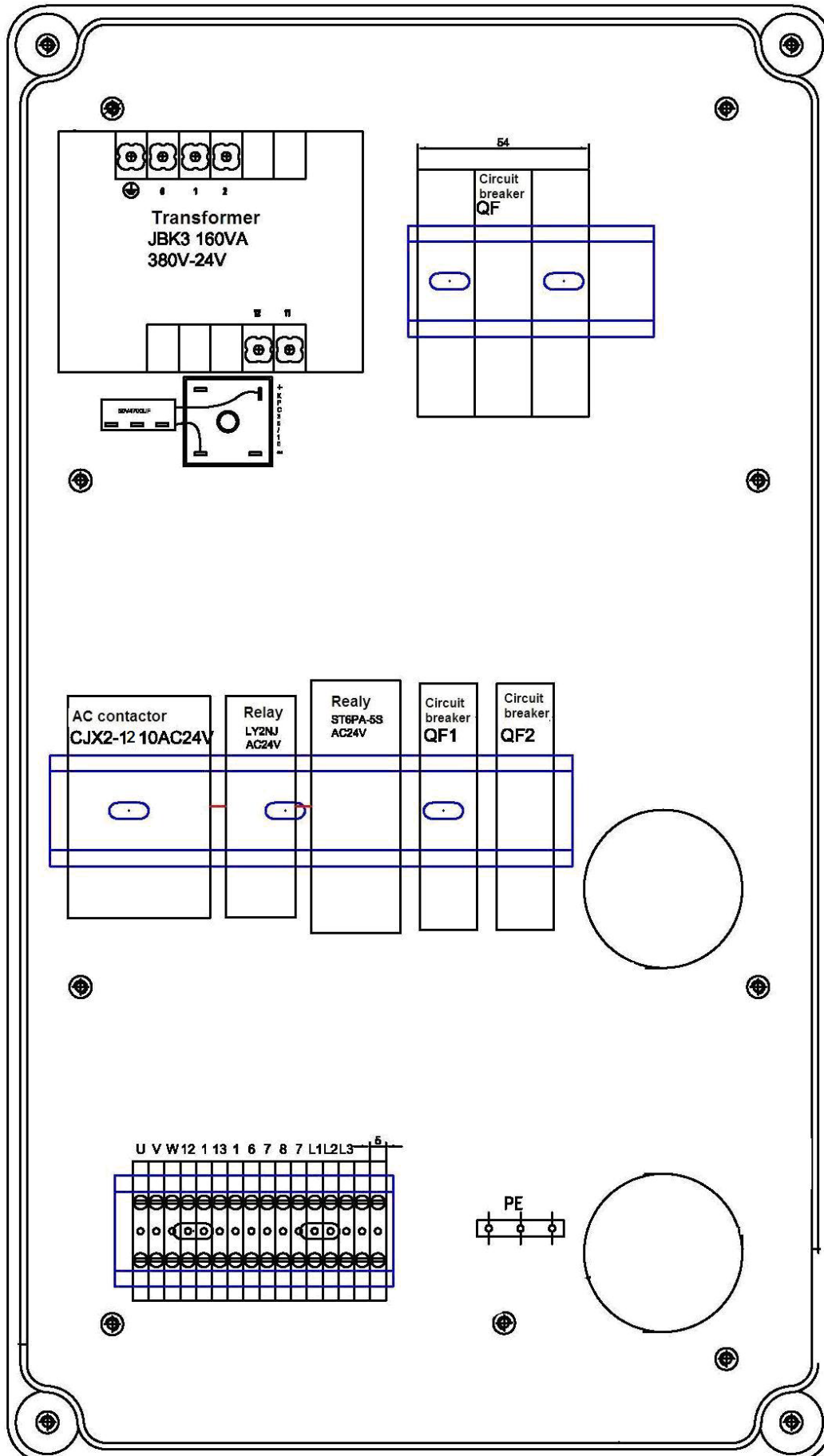

13.6 Exploded views

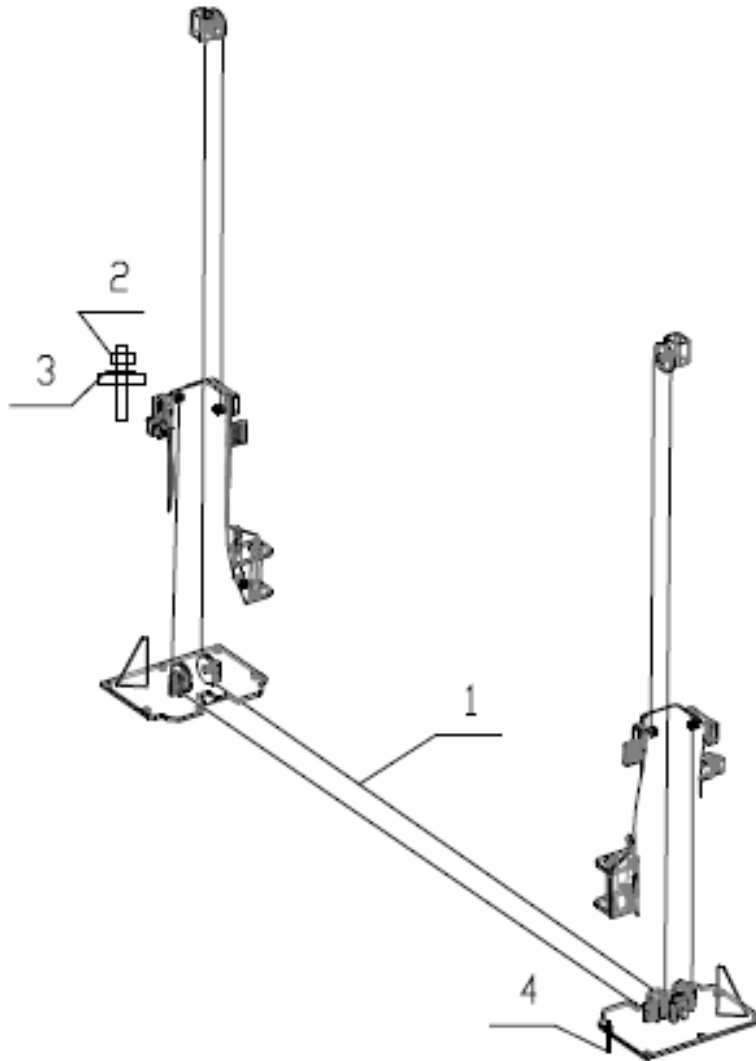

S/N	Name	Drawing	Qty	Property	Grade
1	Steel cable L=7470 mm	FL-8224S-A7	2	Assembly	
2	Hex nut M16	GB/T610-2000	8	Standard	
3	Class C flat washer M16	GB/T95-1985	4	Standard	
4	Expansion bolt M16*173		10	Standard	

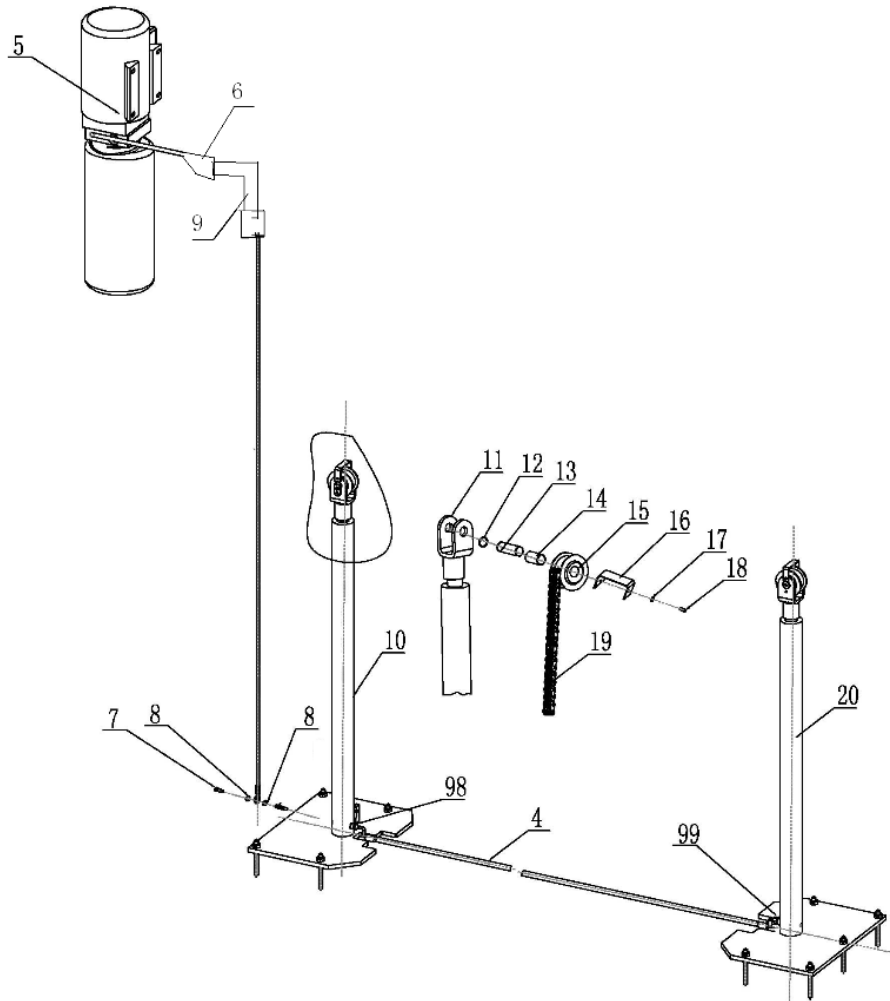

S/N	Name	Drawing	Qty	Property	Grade
4	Rubber oil hose L=2550		1	Assembly	
5	Power unit (electrical release)		1	Assembly	
6	PU oil hose L=500		1	Assembly	
7	Composite connector		2	Assembly	
8	Composite washer	Match with 1/4 connector	4	Standard	
9	Square Connector		1	Assembly	
10	Drive oil cylinder	FL-8224S-A6-B2	1	Assembly	
12	Type B circlip 25	GB/T894.2-1986	4	Standard	
13	Chain wheel shaft	FL-8224-A4-B11	2	Zinc -plating	
14	Bearing 2548	SF-1	2	Standard	
15	Chain wheel	FL-8224-A4-B10	2	Zinc -plating	
16	Baffle plate	FL-8224-A4-B12	2	Zinc -plating	
17	Spring washer M6	GB/T93-1987	4	Standard	
18	Inside hex cylinder head screw M6*10	GB/T70.1-2000	4	Standard	
19	Chain	LH1234-113LGB/6074-1995	2	Standard	
20	Assistant oil cylinder	FL-8224S-A6-B3	1	Assembly	
98	Main oil cylinder connector	FL-8224-A4-B4	1	Zinc -plating	
99	Assistant oil cylinder connector	FL-8224-A4-B5	1	Zinc -plating	

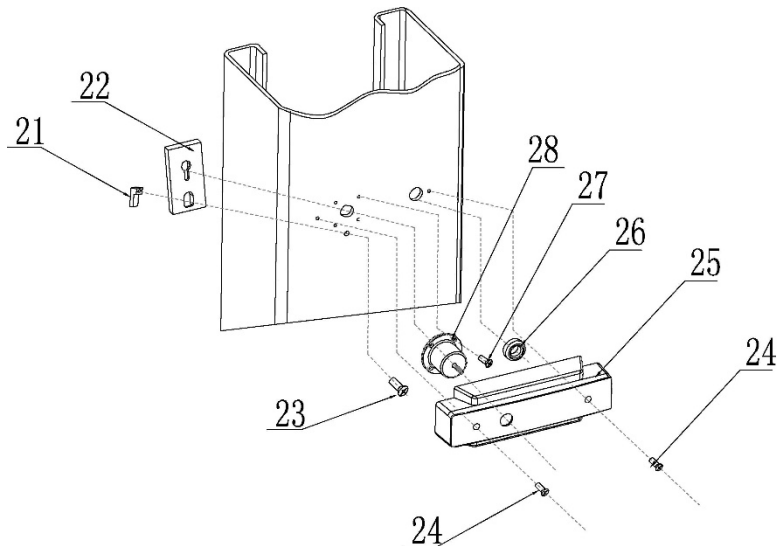

S/N	Name	Drawing	Qty	Property	Grade
21	Positioning block	FL-8224E-A1-B3	4	Zinc plating	
22	Safety locking plate	FL-8224E-A1-B2	4	Zinc plating	
23	Cross cap screw M6*16	GB/T818-2000	4	Standard	
24	Cross cap screw M5*10	GB/T818-2000	8	Standard	
25	Electromagnet protection cover	FL-8224E-A1-B5	4	Plastic	
26	φ20 hose clip	FL-8224-A1-B6	2	Rubber	
27	Cross cap screw M5*10	GB/T818-2000	16	Standard	
28	Tractive electromagnet	FL-8224E-A1-B6	4	Assembly	

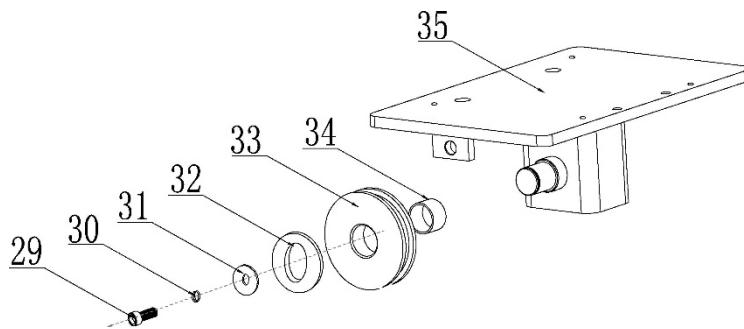

S/N	Name	Drawing	Qty	Property	Grade
29	Hex socket cylinder head screw M8*20	GB/T70.2-2000	2	Standard	
30	Spring washer M8	GB/T93-1987	2	Standard	
31	Retaining ring	FL-8224-A1-B3-C2	2	Zinc plating	
32	Washer	GB/T894.2-1986	2	Zinc plating	
33	Up pulley	FL-8224T-A1-B2	2	Zinc plating	
34	Bearing 2516	SF-1	2	Standard	
35	Top plate	FL-8224T-A1-B3-C1	2	Welded	

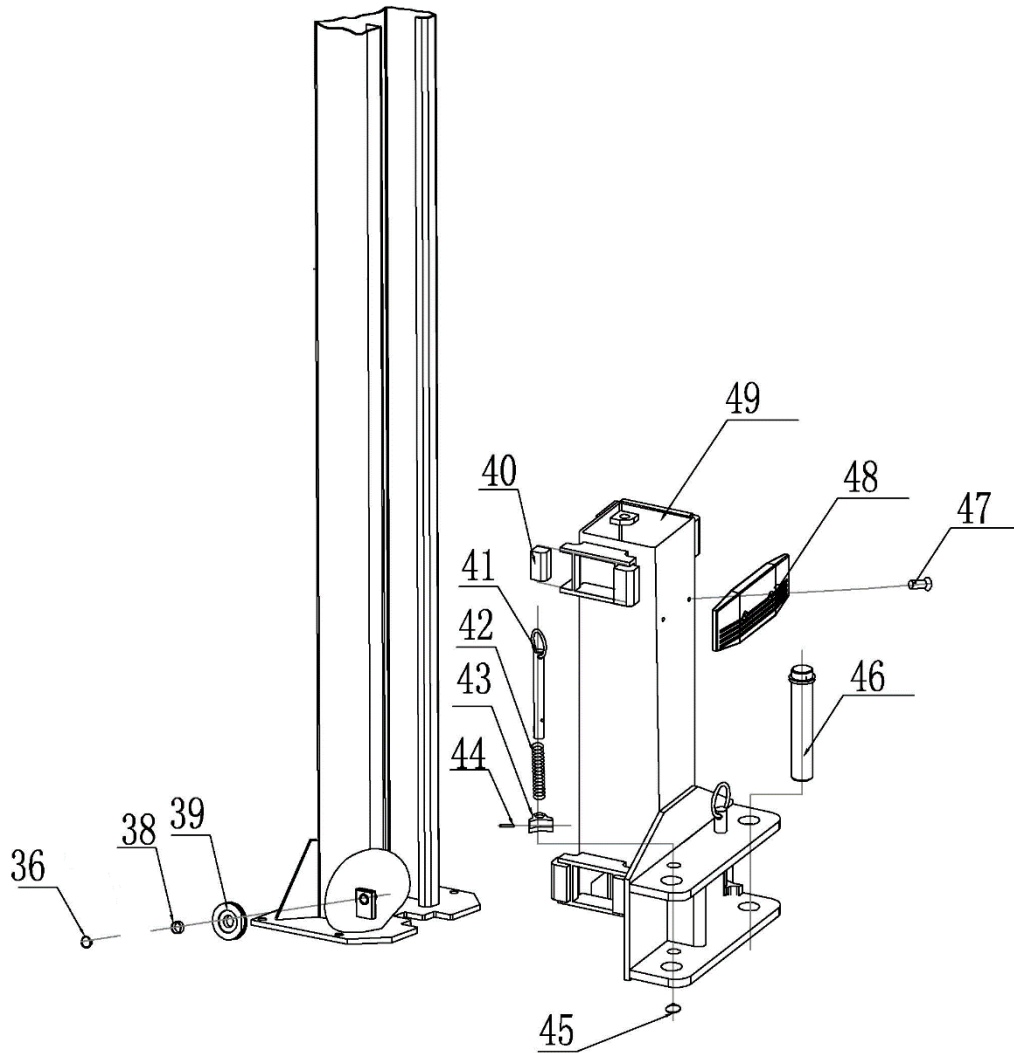

S/N	Name	Drawing	Qty	Property	Grade
36	Type B circlip 25	GB/T894.2-1986	4	Standard	
38	Bearing 2516	SF-1	4	Standard	
39	Down pulley	FL-8224T-A1-B2	4	Zinc plating	
40	Slider	FL-8224T-A3-B2	16	Nylon	
41	Pulling rod	FL-8224-A3-B2	4	Zinc plating	
42	Pressure spring	FL-8224-A3-B5	4	Zinc plating	
43	Teeth block	FL-8224-A3-B6	4	Zinc plating	
44	Elastic pin 5*35	GB/T879.1-2000	4	Standard	
45	Type B circlip 22	GB/T894.2-1986	4	Standard	
46	Pin shaft assembly	FL-8224E-A12	4	Zinc plating	
47	Cross socket flat head screw M8*16	GB/T819.1-2000	4	Standard	
48	Protection rubber pad	FL-8224-A3-B7	2	Rubber	
49	Carriage assembly	FL-8224SE-A3-B1	2	Welded	



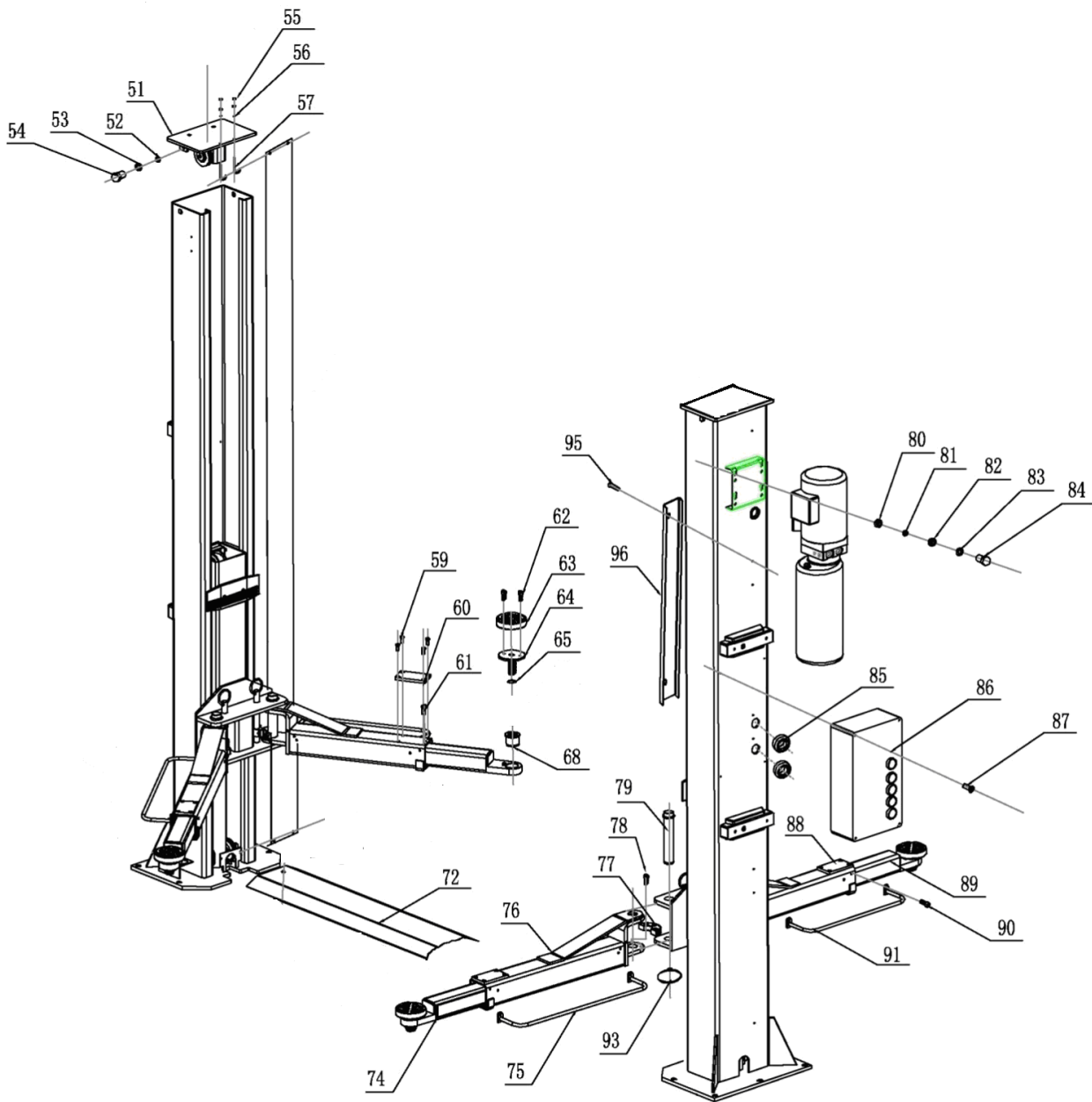

S/N	Name	Drawing	Qty	Property	Grade
51	Top plate	FL-8224T-A1-B3	2	Assembly	
52	Class C flat washer M12	GB/T95-1985	4	Standard	
53	Spring washer M12	GB/T93-1987	4	Standard	
54	Hex head full swivel screw M12*20	GB/T5781-2000	4	Standard	
55	Hex nut M6	GB/T6170-2000	8	Standard	
56	Class C flat washer M6	GB/T95-1985	4	Standard	
57	Rod of chain protection cloth	FL-8224-A13	4	Standard	
58	Chain protection	FL-8224-A11	2	Cloth	
59	Cross socket flat head screw M5*10	GB/T819.1-2000	16	Standard	
60	Rectangular protection pad	FL-8224-A7-B7	4	Rubber	
61	Cross socket flat head screw M8*10	GB/T819.1-2000	4	Standard	
62	Inside hex sunken head screw M8*20	GB/T70.3-2000	8	Standard	
63	Round lifting pad	FL-8224-A7-B3-C4	4	Rubber	

S/N	Name	Drawing	Qty	Property	Grade
64	Lifting tray	FL-8224-A7-B3-C1	4	Assembly	
65	Type B circlip 30	GB/T894.2-1986	4	Standard	
68	Inside swivel sheath	FL-8224-A7-B3-C3	4	Q235A	
72	Base plate	FL-8224T-A10	1	Q235A	
74	Long tensile arm	TW-236E-A20-B1	2	Welded	
75	Long feet protection fender	FL-8224-A18-B4	2	Welded	
76	Long arm	FL-8224-A18-B1	2	Welded	
77	Teeth block	FL-8224-A7-B5	4	Q235A	
78	Hex socket cap screw M10*20	GB/T70.1-2000	12	Standard	
79	Arm shaft	FL-8224-A12	4	Welded	
80	Hex nut M8	GB/T6170-2000	4	Standard	
81	Spring washer M8	GB/T93-1987	4	Standard	
82	Anti-shock pad	FL-8224-A14	4	Rubber	
83	Class C flat washer M8	GB/T95-1985	4	Standard	
84	Hex head full swivel screw M8*35	GB/T5781-2000	4	Standard	
85	Φ40 hose clip	FL-8224-A1-B7	2	Rubber	
86	Control box	FL-8224E	1	Assembly	
87	Cross cap screw M5*10	GB/T818-2000	4	Standard	
88	Short arm	FL-8224S-A8-B1	2	Welded	
89	Short tensile arm	FL-8224S-A8-B2	2	Welded	
90	Hex socket cylinder head screw M8*12	GB/T70.2-2000	8	Standard	
91	Short feet protection fender	FL-8224S-A8-B3	2	Welded	
93	Type B circlip 38	GB/T894.2-1986	4	Standard	

13.7 Spare parts list

S/N	Name	Spec.	Qty	Pic.	Grade
1	Power switch	LW26GS-20/04	1		
2	Button	LAY711BN12	1		
3	Power indicator	AD17-22G-AC24	1		
4	Transformer	JBK3-160VA400V-24V JBK3-160VA230V-24V	1		
5	AC contactor	CJX2-1210/AC24V	1		
6	Circuit breaker	DZ47-63 C16/3P DZ47-63 C32/2P	1		
7	Circuit breaker	DZ47-63 C3/1P	1		
9	Limit switch	ME8108	1		
11	Emergency stop	LAY701ZS42	1		
12	Bridge rectifier	KBPC5A-35A	1		
13	Capacitor	4700UF/50A	1		
14	Relay	LY2NJ/AC24	1		
15	Relay holder	PTF-08A	1		
16	time relay	ST6PA-5S/AC24V	1		
17	Time relay holder	PYF-08AE	1		
18	Control box	380*260*135	1		

Mechanical spare parts list

S/N	Name	Drawing#	Qty	Property	Grade
1	Slider	FL-8224T-A3-B2	16	Nylon 1010	
2	Rubber lifting pad	FL-8224-A7-B3-C4 8224E-A7-B4-C4	4	Rubber	
3	Y-shape seal ring	KD 63*48*10	1		
4	O-shape seal ring	(ID)23.6*3.55	1		
5	Anti-dust ring	DHS 40*48*5/6.5	1		







The company

**Twin Busch GmbH | Amperestr. 1 | D-64625 Bensheim**

hereby declares that the **2-post vehicle lift**

**TW242E-400, TW242E-230, TW242A-400, TW242A-230,  
TW242GE-400, TW242GE-230, TW236E-400, TW236E-230  
3.600 kg, 4.200 kg**

Serial number:

in these configurations we have placed on the marked complies with the relevant essential health and safety requirements of the following EC-directive(s) in its/their current version(s).

EC-directive(s)

**2006/42/EC  
2014/35/EU**

**Machinery  
Low Voltage**

Applied harmonized standards and regulations

**EN 1493:2022  
EN 60204-1:2018**

**Vehicle Lifts  
Safety of Machinery – Electrical Equipment  
of Machines**

CE Certificate

**M6A 087411 0039 Rev. 01  
N8MA 087411 0040 Rev. 01**

date of issue: 31.05.2023  
place of issue: München  
technical file no.: 646642302001

Certification body

TÜV SÜD Product Service GmbH,  
Ridlerstraße 65,  
D-80339 München  
Notified Body Appointment No.: 0123

**In the case of improper use, as well as in the case of assembling, modification or changes which are not agreed with us, this declaration will lose its validity.**

Authorized person to compile technical documentation is: Michael Glade (adress as below)

  
  
**TWIN BUSCH GmbH**  
Amperestr. 1 · 64625 Bensheim  
Tel. 06251 / 70585-0 · Fax: 70585-29

Authorized signatory: Michael Glade  
Bensheim, 07.11.2023 Qualitätsmanagement

**Twin Busch GmbH | Amperestr. 1 | D-64625 Bensheim**  
twinbusch.de | E-Mail: info@twinbusch.de | Tel.: +49 (0)6251-70585-0



*You can find more products at:*

***[twinbusch.co.uk](http://twinbusch.co.uk)***

---

**Twin Busch UK LTD**  
Kettering  
Northants NN16 8PS

Tel.: +44 (0) 1536 522 960  
E-Mail: [info@twinbusch.co.uk](mailto:info@twinbusch.co.uk)  
Web: [www.twinbusch.co.uk](http://www.twinbusch.co.uk)

The technical specifications and illustrations provided in the user manual are not binding. Our products are subject to technical changes, so the delivered condition may vary.